



Multi-turn actuators

SA 07.2 – SA 16.2

SAR 07.2 – SAR 16.2

Control unit: electronic (MWG)

with actuator controls

AC 01.2 Non-Intrusive

Control

→ Parallel

Profibus DP

Profinet

Modbus RTU

Modbus TCP/IP

Foundation Fieldbus

HART



Read operation instructions first.

- Observe safety instructions.
- These operation instructions are part of the product.
- Retain operation instructions during product life.
- Pass on instructions to any subsequent user or owner of the product.

Purpose of the document:

This document contains information for installation, commissioning, operation and maintenance staff. It is intended to support device installation and commissioning.

Reference documents:

- Manual (Operation and setting) of actuator controls AC 01.2 Parallel

Reference documents can be downloaded from the Internet (www.auma.com) or ordered directly from AUMA (refer to <Addresses>).

Table of contents	Page
1. Safety instructions.....	5
1.1. Basic information on safety	5
1.2. Range of application	5
1.3. Applications in Ex zone 22 (option)	6
1.4. Warnings and notes	6
1.5. References and symbols	7
2. Identification.....	8
2.1. Name plate	8
2.2. Short description	11
3. Transport, storage and packaging.....	12
3.1. Transport	12
3.2. Storage	14
3.3. Packaging	14
4. Assembly.....	16
4.1. Mounting position	16
4.2. Handwheel fitting	16
4.3. Multi-turn actuator: mount to valve/gearbox	16
4.3.1. Output drive type A	16
4.3.1.1. Stem nut: finish machining	17
4.3.1.2. Multi-turn actuator (with output drive type A): mount to valve	18
4.3.2. Output drive types B	19
4.3.2.1. Multi-turn actuator with output drive types B: mount to valve/gearbox	20
4.4. Accessories for assembly	21
4.4.1. Stem protection tube for rising valve stem	21
4.5. Mounting positions of local controls	22
4.5.1. Mounting positions: modify	22
5. Electrical connection.....	23
5.1. Basic information	23
5.2. S/SH electrical connection (AUMA plug/socket connector)	25
5.2.1. Terminal compartment : open	26
5.2.2. Cable connection	27

5.2.3.	Terminal compartment : close	28
5.3.	Accessories for electrical connection	29
5.3.1.	Controls mounted on wall bracket	29
5.3.2.	Parking frame	30
5.3.3.	DS intermediate frame for double sealing	30
5.3.4.	External earth connection	31
6.	Operation.....	32
6.1.	Manual operation	32
6.1.1.	Engage manual operation	32
6.1.2.	Manual operation: disengage	32
6.2.	Motor operation	33
6.2.1.	Local actuator operation	33
6.2.2.	Actuator operation from remote	34
6.3.	Menu navigation via push buttons (for settings and indications)	34
6.3.1.	Menu layout and navigation	35
6.4.	User level, password	36
6.4.1.	Password entry	36
6.4.2.	Password change	37
6.5.	Language in the display	37
6.5.1.	Language change	37
7.	Indications.....	39
7.1.	Indications during commissioning	39
7.2.	Indications in the display	39
7.2.1.	Feedback indications from actuator and valve	40
7.2.2.	Status indications according to AUMA classification	43
7.2.3.	Status indications according to NAMUR recommendation	43
7.3.	Indication lights of local controls	45
7.4.	Optional indications	46
7.4.1.	Mechanical position indication (self-adjusting)	46
7.4.2.	Mechanical position indication via indicator mark (not self-adjusting)	46
8.	Signals (output signals).....	47
8.1.	Status signals via output contacts (digital outputs)	47
8.1.1.	Assignment of outputs	47
8.1.2.	Coding the outputs	47
8.2.	Analogue signals	47
9.	Commissioning (basic settings).....	49
9.1.	Type of seating: set	49
9.2.	Torque switching: set	50
9.3.	Limit switching: set	51
9.4.	Test run	53
9.4.1.	Direction of rotation at mechanical position indicator: check	54
9.4.2.	Direction of rotation at hollow shaft/stem: check	55
9.4.3.	Limit switching: check	55
10.	Commissioning (settings/options in the actuator).....	57
10.1.	Switch compartment: open/close	57
10.2.	Mechanical position indicator (self-adjusting)	58
10.2.1.	Mechanical position indicator: set	58
10.2.2.	Gear stage of the reduction gearing: test/set	59

10.3.	Mechanical position indication via indicator mark (not self-adjusting)	60
10.3.1.	Mechanical position indicator: set	60
10.3.2.	Gear stage of the reduction gearing: test/set	60
11.	Corrective action.....	63
11.1.	Faults during operation/commissioning	63
11.2.	Fault indications and warning indications	63
11.3.	Fuses	67
11.3.1.	Fuses within the actuator controls	67
11.3.2.	Motor protection (thermal monitoring)	69
12.	Servicing and maintenance.....	70
12.1.	Preventive measures for servicing and safe operation	70
12.2.	Maintenance	70
12.3.	Disposal and recycling	71
13.	Technical data.....	72
13.1.	Technical data Multi-turn actuators	72
13.2.	Technical data Actuator controls	74
14.	Spare parts.....	79
14.1.	Multi-turn actuators SA 07.2 – SA 16.2/SAR 07.2 – SAR 16.2	79
14.2.	AC 01.2 actuator controls	81
15.	Certificates.....	83
15.1.	Declaration of Incorporation and EC Declaration of Conformity	83
	Index.....	86
	Addresses.....	89

1. Safety instructions

1.1. Basic information on safety

Standards/directives	<p>Our products are designed and manufactured in compliance with recognised standards and directives. This is certified in a Declaration of Incorporation and an EU Declaration of Conformity.</p> <p>The end user or the contractor must ensure that all legal requirements, directives, guidelines, national regulations and recommendations with respect to assembly, electrical connection, commissioning and operation are met at the place of installation.</p>
Safety instructions/warnings	<p>All personnel working with this device must be familiar with the safety and warning instructions in this manual and observe the instructions given. Safety instructions and warning signs on the device must be observed to avoid personal injury or property damage.</p>
Qualification of staff	<p>Assembly, electrical connection, commissioning, operation, and maintenance must be carried out by suitably qualified personnel authorised by the end user or contractor of the plant only.</p> <p>Prior to working on this product, the staff must have thoroughly read and understood these instructions and, furthermore, know and observe officially recognised rules regarding occupational health and safety.</p>
Commissioning	<p>Prior to commissioning, it is important to check that all settings meet the requirements of the application. Incorrect settings might present a danger to the application, e.g. cause damage to the valve or the installation. The manufacturer will not be held liable for any consequential damage. Such risk lies entirely with the user.</p>
Operation	<p>Prerequisites for safe and smooth operation:</p> <ul style="list-style-type: none">• Correct transport, proper storage, mounting and installation, as well as careful commissioning.• Only operate the device if it is in perfect condition while observing these instructions.• Immediately report any faults and damage and allow for corrective measures.• Observe recognised rules for occupational health and safety.• Observe national regulations.• During operation, the housing warms up and surface temperatures > 60 °C may occur. To prevent possible burns, we recommend checking the surface temperature using an appropriate thermometer and wearing protective gloves, if required, prior to working on the device.
Protective measures	<p>The end user or the contractor are responsible for implementing required protective measures on site, such as enclosures, barriers, or personal protective equipment for the staff.</p>
Maintenance	<p>To ensure safe device operation, the maintenance instructions included in this manual must be observed.</p> <p>Any device modification requires prior written consent of the manufacturer.</p>

1.2. Range of application

AUMA multi-turn actuators are designed for the operation of industrial valves, e.g. globe valves, gate valves, butterfly valves, and ball valves.

Other applications require explicit (written) confirmation by the manufacturer.

The following applications are not permitted, e.g.:

- Industrial trucks according to EN ISO 3691
- Lifting appliances according to EN 14502
- Passenger lifts according to DIN 15306 and 15309
- Service lifts according to EN 81-1/A1

- Escalators
- Continuous duty
- Buried service
- Continuous submersion (observe enclosure protection)
- Potentially explosive areas, with the exception of zone 22
- Radiation exposed areas in nuclear power plants

No liability can be assumed for inappropriate or unintended use.

Observance of these operation instructions is considered as part of the device's designated use.

Information These operation instructions are only valid for the "clockwise closing" standard version, i.e. driven shaft turns clockwise to close the valve.

1.3. Applications in Ex zone 22 (option)

Actuators of the indicated series basically meet the requirements for applications in dust hazardous locations of ZONE 22 in compliance with the ATEX directive 2014/34/EU.

To comply with all requirements of the ATEX directive, observe the following points:

- Actuators are marked with the explosion protection designation II3D... for use in ZONE 22.
- Maximum surface temperature of actuators
 - T150 °C for ambient temperatures up to +60 °C or
 - T190 °C for ambient temperatures up to +80 °C.

Increased dust deposit on the equipment was not considered for the determination of the maximum surface temperature.

- The following conditions must be fulfilled to respect the maximum permissible surface temperatures at the actuator:
 - Respecting types of duty and technical manufacturer data
 - Correct connection of thermal motor protection (thermoswitches or PTC thermistor)

Ambient temperature	Tripping temperature Thermal motor protection	Maximum surface temperature
up to +60 °C	140 °C	T150 °C
up to +80 °C	155 °C	T190 °C

- The connector may only be connected or disconnected when not live.
- The cable glands and cable entries used have to meet the requirements of category II3D and must at least comply with enclosure protection IP67.
- The actuators must be connected by means of an external earth connection (accessory part) to the equipotential earth bonding or integrated into an earthed piping system.
- To ensure combustible dust hazard protection, seal hollow shaft against ingress of dust:
 - Using threaded plug (ref. no. 511.0) and appropriate seal
 - Using metallic stem protection tube, protective cap and V-seal (ref. no. 568.1, 568.2, 568.3) for rising valve stem
- As a general rule, the requirements of IEC 60079 Parts 14 and 17 must be respected in dust hazardous locations. During commissioning, service, and maintenance, special care as well as qualified and trained personnel are required for safe actuator operation.

1.4. Warnings and notes

The following warnings draw special attention to safety-relevant procedures in these operation instructions, each marked by the appropriate signal word (DANGER, WARNING, CAUTION, NOTICE).



Indicates an imminently hazardous situation with a high level of risk. Failure to observe this warning could result in death or serious injury.



Indicates a potentially hazardous situation with a medium level of risk. Failure to observe this warning could result in death or serious injury.



Indicates a potentially hazardous situation with a low level of risk. Failure to observe this warning may result in minor or moderate injury. May also be used with property damage.



Potentially hazardous situation. Failure to observe this warning may result in property damage. Is not used for personal injury.

Arrangement and typographic structure of the warnings



Type of hazard and respective source!

Potential consequence(s) in case of non-observance (option)

- Measures to avoid the danger
- Further measure(s)

Safety alert symbol  warns of a potential personal injury hazard.

The signal word (here: DANGER) indicates the level of hazard.

1.5. References and symbols

The following references and symbols are used in these instructions:

Information The term **Information** preceding the text indicates important notes and information.

 Symbol for CLOSED (valve closed)

 Symbol for OPEN (valve open)

 Important information before the next step. This symbol indicates what is required for the next step or what has to be prepared or observed.

M ▶ **Via the menu to parameter**

Describes the path within the menu to the parameter. By using the push buttons of the local controls you may quickly find the desired parameter in the display.

< > **Reference to other sections**

Terms in brackets shown above refer to other sections of the document which provide further information on this topic. These terms are either listed in the index, a heading or in the table of contents and may easily be located.

2. Identification

2.1. Name plate

Figure 1: Arrangement of name plates

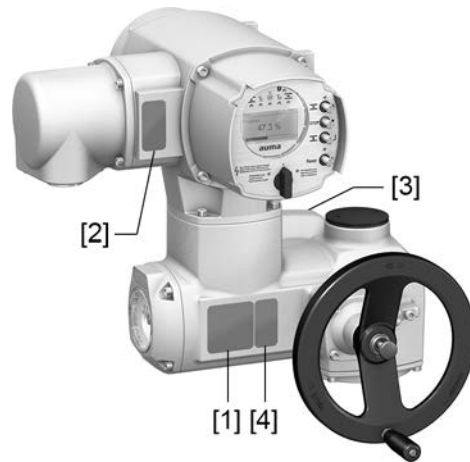

- [1] Actuator name plate
- [2] Actuator controls name plate
- [3] Motor name plate
- [4] Additional plate, e.g. KKS plate (Power Plant Classification System)

Actuator name plate

Figure 2: Actuator name plate (example)



auma (= manufacturer logo); **CE** (= CE mark)

- [1] Name of manufacturer
- [2] Address of manufacturer
- [3] **Type designation**
- [4] **Order number**
- [5] **Serial number**
- [6] Speed
- [7] Torque range in direction CLOSE
- [8] Torque range in direction OPEN
- [9] Type of lubricant
- [10] Permissible ambient temperature
- [11] Can be assigned as an option upon customer request
- [12] Enclosure protection
- [13] Data Matrix code

Name plate for actuator controls (example)

Figure 3: Name plate for actuator controls (example)

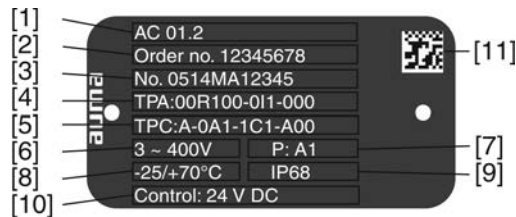

- [1] **Type designation**
- [2] **Order number**
- [3] **Serial number**
- [4] **Actuator terminal plan**
- [5] Actuator controls terminal plan
- [6] Mains voltage
- [7] **AUMA power class for switchgear**
- [8] Permissible ambient temperature
- [9] Enclosure protection
- [10] **Control**
- [11] Data Matrix code

Motor name plate

Figure 4: Motor name plate (example)



auma (= manufacturer logo); **CE** (= CE mark)

- [1] Motor type
- [2] Motor article number
- [3] Serial number
- [4] Current type, mains voltage
- [5] Rated power
- [6] Rated current
- [7] Type of duty
- [8] Enclosure protection
- [9] Motor protection (temperature protection)
- [10] Insulation class
- [11] Speed
- [12] Power factor cos phi
- [13] Mains frequency
- [14] Data Matrix code

Descriptions referring to name plate indications

Type designation Figure 5: Type designation (example)

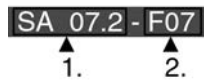

1. Type and size of actuator
2. Flange size

Type and size

These instructions apply to the following devices types and sizes:

- SA.....= Type = Multi-turn actuator for open-close duty
Sizes and generation: 07.2, 07.6, 10.2, 14.2, 14.6, 16.2
- SAR.... = Type = Multi-turn actuator for modulating duty
Sizes and generation: 07.2, 07.6, 10.2, 14.2, 14.6, 16.2
- AC = Type = AC actuator controls
Size and generation: 01.2

Order number The product can be identified using this number and the technical data as well as order-related data pertaining to the device can be requested.

Please always state this number for any product inquiries.

On the Internet at <http://www.auma.com> > Service & Support >myAUMA, we offer a service allowing authorised users to download order-related documents such as wiring diagrams and technical data (both in German and English), inspection certificate and the operation instructions when entering the order number.

Actuator serial number

Table 1:

Description of serial number (with example 0516MD12345)		
05	16	MD12345
05	Positions 1+2: Assembly in week = week 05	
	16	Positions 3+4: Year of manufacture = 2016
	MD12345	Internal number for unambiguous product identification

Actuator terminal plan Position 9 after **TPA**: Position transmitter version

I, Q = MWG (magnetic limit and torque transmitter)

AUMA power class for switchgear

The switchgear used in the actuator controls (reversing contactors/thyristors) are classified according to AUMA power classes (e.g. A1, B1,). The power class defines the max. permissible rated power (of the motor) the switchgear has been designed for. The rated power (nominal power) of the actuator motor is indicated in kW on the motor name plate. For the assignment of the AUMA power classes to the nominal power of the motor types, refer to the separate electrical data sheets.

For switchgear without assignment to any power classes, the actuator controls name plate does not indicate the power class but the max. rated power in kW.

Control

Table 2:

Control examples (indications on actuator controls name plate)	
Input signal	Description
24 V DC	Control voltage 24 V DC for OPEN - CLOSE control via digital inputs (OPEN, STOP, CLOSE)
48 V DC	Control voltage 48 V DC OPEN - CLOSE control via digital inputs (OPEN, STOP, CLOSE)
60 V DC	Control voltage 60 V DC OPEN - CLOSE control via digital inputs (OPEN, STOP, CLOSE)
115 V AC	Control voltage 115 V AC for OPEN - CLOSE control via digital inputs (OPEN, STOP, CLOSE)
0/4 – 20 mA	Input current for setpoint control via analogue input

Data Matrix code When registered as authorised user, you may use the **AUMA Support App** to scan the Data Matrix code and directly access the order-related product documents without having to enter order number or serial number.

Figure 6: Link to the AUMA App:



For further Service & Support, software/apps/... refer to www.auma.com.

2.2. Short description

Multi-turn actuator Definition in compliance with EN 15714-2/EN ISO 5210:
 A multi-turn actuator is an actuator which transmits torque to a valve for at least one full revolution. It is capable of withstanding thrust.
 AUMA multi-turn actuators SA 07.2 – SA 16.2/SAR 07.2 – SAR 16.2 are driven by an electric motor and are capable of withstanding thrust in combination with output drive type A. For manual operation, a handwheel is provided. Switching off in end positions may be either by limit or torque seating. Actuator controls are required to operate or process the actuator signals.

Actuator controls AC 01.2 actuator controls are used to operate AUMA actuators and are supplied ready for use. The actuator controls may be mounted directly to the actuator or separately on a wall bracket.

The functions of AC 01.2 actuator controls include standard valve control in OPEN-CLOSE duty, positioning, process control, logging of operating data right through to diagnostic functions.

Local controls/ AUMA CDT Operation, setting, and display can be performed directly at the actuator controls.

When set to local control, it is possible to

- operate the actuator via the local controls (push buttons and display) and perform settings (contents of these instructions).
- read in or out data or modify and save settings via AUMA CDT software (accessory), using a computer (laptop or PC). The connection between computer and actuator controls is wireless via Bluetooth interface (not included in these instructions).

- Intrusive - Non-Intrusive**
- Intrusive version (control unit: electromechanical):
Limit and torque setting is performed via switches in the actuator.
 - Non-Intrusive version (control unit: electronic):
Limit and torque setting is performed via the controls, without removal of actuator or actuator controls covers. For this purpose, the actuator is equipped with an MWG (magnetic limit and torque transmitter), also capable to supply analogue torque feedback signals/torque indication and analogue position feedback signals/position indication at the actuator controls output.

3. Transport, storage and packaging

3.1. Transport

For transport to place of installation, use sturdy packaging.



Hovering load!

Risk of death or serious injury.

- Do NOT stand below hovering load.
- Attach ropes or hooks for the purpose of lifting by hoist only to housing and NOT to handwheel.
- Actuators mounted on valves: Attach ropes or hooks for the purpose of lifting by hoist to valve and NOT to actuator.
- Actuators mounted to gearboxes: Attach ropes or hooks for the purpose of lifting by hoist only to the gearbox using eyebolts and NOT to the actuator.
- Actuators mounted to controls: Attach ropes or hooks for the purpose of lifting by hoist only to the actuator and NOT to the controls.
- Respect total weight of combination (actuator, actuator controls, gearbox, valve)
- Secure load against falling down, sliding or tilting.
- Perform lift trial at low height to eliminate any potential danger e.g. by tilting.

Figure 7: Example: Lifting the actuator



Table 3:

Weights for multi-turn actuators SA 07.2 – SA 16.2 / SAR 07.2 – SAR 16.2 with 3-phase AC motors

Type designation Actuator	Motor type ¹⁾	Weight ²⁾
		approx. [kg]
SA 07.2/ SAR 07.2	VD...	19
	AD...	20
SA 07.6/ SAR 07.6	VD...	20
	AD...	21
SA 10.2/ SAR 10.2	VD...	22
	AD...	25
SA 14.2/ SAR 14.2	VD...	44
	AD...	48

Weights for multi-turn actuators SA 07.2 – SA 16.2 / SAR 07.2 – SAR 16.2 with 3-phase AC motors		
Type designation Actuator	Motor type ¹⁾	Weight ²⁾
		approx. [kg]
SA 14.6/ SAR 14.6	VD...	46
	AD...	53
SA 16.2/ SAR 16.2	VD...	67
	AD...	83

- 1) Refer to motor name plate
- 2) Indicated weight includes AUMA NORM multi-turn actuator with 3-phase AC motor, electrical connection in standard version, output drive type B1 and handwheel. For other output drive types, heed additional weights.

Table 4:

Weights for multi-turn actuators SA 07.2 – SA 16.2 / SAR 07.2 – SAR 16.2 With 1-phase AC motors		
Type designation Actuator	Motor type ¹⁾	Weight ²⁾
		approx. [kg]
SA 07.2/ SAR 07.2	VE...	25
	AE...	28
SA 07.6/ SAR 07.6	VE...	25
	AE...	28
	AC...	37
SA 10.2/ SAR 10.2	VE...48-4...	28
	VE...48-2...	31
	AC... 56-4...	40
	AC... 56-2...	43
SA 14.2/ SAR 14.2	VE...	59
	VC...	61
	AC...	63
SA 14.6/ SAR 14.6	VE...	63
	VC...	66

- 1) Refer to motor name plate
- 2) Indicated weight includes AUMA NORM multi-turn actuator with 1-phase AC motor, electrical connection in standard version, output drive type B1 and handwheel. For other output drive types, heed additional weights.

Table 5:

Weights for multi-turn actuators SA 07.2 – SA 16.2 / SAR 07.2 – SAR 16.2 With DC motors		
Type designation Actuator	Motor type ¹⁾	Weight ²⁾
		approx. [kg]
SA 07.2/ SAR 07.2	FN... 63-...	29
	FN... 71-...	32
SA 07.6/ SAR 07.6	FN... 63-...	30
	FN... 80-...	44
SA 10.2/ SAR 10.2	FN... 63-...	33
	FN... 71-...	36
	FN... 90-...	56
SA 14.2/ SAR 14.2	FN... 71-... / FN... 80-...	68
	FN... 90-...	100

Weights for multi-turn actuators SA 07.2 – SA 16.2 / SAR 07.2 – SAR 16.2		
With DC motors		
Type designation Actuator	Motor type ¹⁾	Weight ²⁾ approx. [kg]
SA 14.6/ SAR 14.6	FN... 80-... / FN... 90-...	76
	FN... 112-...	122
SA 16.2/ SAR 16.2	FN... 100-...	123

1) Refer to motor name plate

2) Indicated weight includes AUMA NORM multi-turn actuator with DC motor, electrical connection in standard version, output drive type B1 and handwheel. For other output drive types, heed additional weights.

Table 6:

Weights for output drive type A 07.2 – A 16.2		
Type designation	Flange size	[kg]
A 07.2	F07	1.1
	F10	1.3
A 10.2	F10	2.8
A 14.2	F14	6.8
A 16.2	F16	11.7

Table 7:

Weights for output drive type AF 07.2 – AF 16.2		
Type designation	Flange size	[kg]
AF 07.2	F10	5.2
AF 07.6	F10	5.2
AF 10.2	F10	5.5
AF 14.2	F14	13.7
AF 16.2	F16	23

3.2. Storage

NOTICE

Danger of corrosion due to inappropriate storage!

- Store in a well-ventilated, dry room.
- Protect against floor dampness by storage on a shelf or on a wooden pallet.
- Cover to protect against dust and dirt.
- Apply suitable corrosion protection agent to uncoated surfaces.

NOTICE

Damage on display caused by temperatures below permissible level!

- AC actuator controls **MUST NOT** be stored below -30 °C .

Long-term storage

For long-term storage (more than 6 months), observe the following points:

1. Prior to storage:
Protect uncoated surfaces, in particular the output drive parts and mounting surface, with long-term corrosion protection agent.
2. At an interval of approx. 6 months:
Check for corrosion. If first signs of corrosion show, apply new corrosion protection.

3.3. Packaging

Our products are protected by special packaging for transport when leaving the factory. The packaging consists of environmentally friendly materials which can easily

be separated and recycled. We use the following packaging materials: wood, cardboard, paper, and PE foil. For the disposal of the packaging material, we recommend recycling and collection centres.

4. Assembly

4.1. Mounting position

The product described in this document can be operated in any mounting position.

Restriction: When using oil instead of grease within the actuator gear housing, the hollow shaft mounting position must be perpendicular, with the flange pointing downward. The type of lubricant used is indicated on the actuator name plate (short designation **F**...= grease; **O**...= oil).

4.2. Handwheel fitting

Information For transport reason, handwheels with a diameter of 400 mm and larger are supplied separately within the scope of delivery.

Figure 8: Handwheel

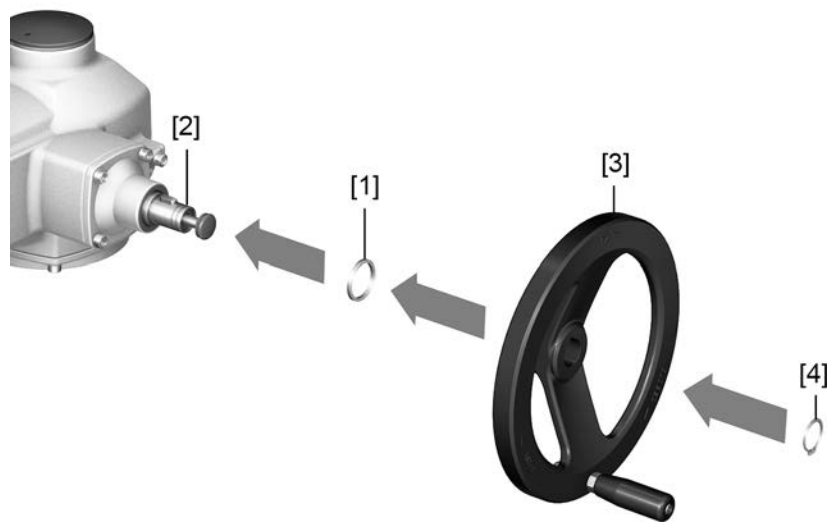

- [1] Spacer
- [2] Input shaft
- [3] Handwheel
- [4] Retaining ring

1. If required, fit spacer [1] on input shaft [2].
2. Slip handwheel [3] onto input shaft.
3. Secure handwheel [3] using the retaining ring [4] supplied.

Information The retaining ring [4] (together with these operation instructions) is stored in a weatherproof bag, which is attached to the device prior to delivery.

4.3. Multi-turn actuator: mount to valve/gearbox

NOTICE

Danger of corrosion due to damage to paint finish and condensation!

- Touch up damage to paint finish after work on the device.
- After mounting, connect the device immediately to electrical mains to ensure that heater minimises condensation.

4.3.1. Output drive type A

- Application**
- Output drive for rising, non-rotating valve stem
 - Capable of withstanding thrust

Design Output mounting flange [1] with axial bearing stem nut [2] form one unit. Torque is transmitted to valve stem [3] via stem nut [2].

Figure 9: Design of output drive type A

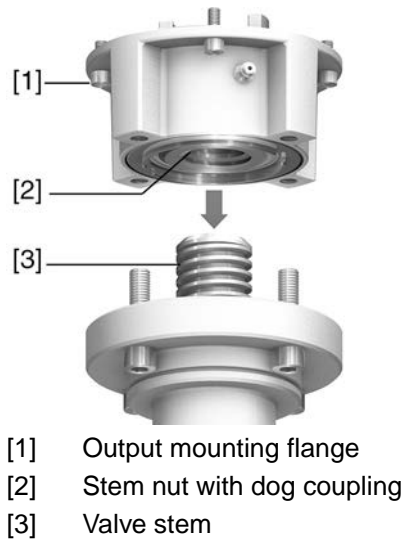

Information To adapt the actuators to available output drive types A with flanges F10 and F14 (year of manufacture: 2009 and earlier), an adapter is required. The adapter can be ordered from AUMA.

4.3.1.1. Stem nut: finish machining

✓ This working step is only required if stem nut is supplied unbored or with pilot bore.

Figure 10: Output drive type A

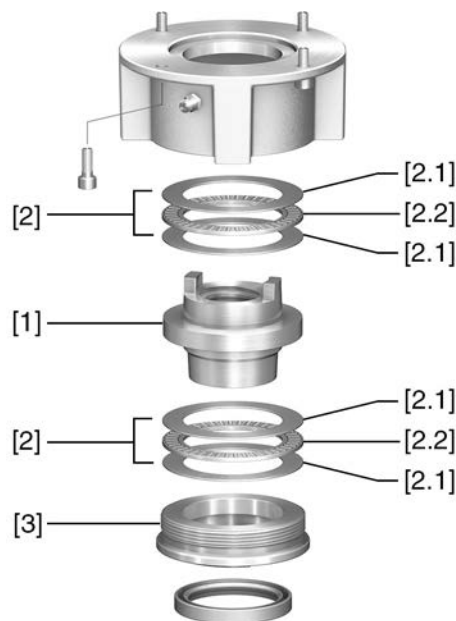

- [1] Stem nut
- [2] Axial needle roller bearing
- [2.1] Axial bearing washer
- [2.2] Axial needle roller and cage assembly
- [3] Spigot ring

1. Remove spigot ring [3] from output drive.
2. Remove stem nut [1] together with axial needle roller bearings [2].
3. Remove axial bearing washers [2.1] and axial needle roller and cage assemblies [2.2] from stem nut [1].

4. Drill and bore stem nut [1] and cut thread.
Information: When fixing in the chuck, make sure stem nut runs true!
5. Clean the machined stem nut [1].
6. Apply sufficient Lithium soap EP multi-purpose grease to axial needle roller and cage assemblies [2.2] and axial bearing washers [2.1], ensuring that all hollow spaces are filled with grease.
7. Place greased axial needle roller and cage assemblies [2.2] and axial bearing washers [2.1] onto stem nut [1].
8. Re-insert stem nut [1] with bearings [2] into output drive.
Information: Ensure that dogs or splines are placed correctly in the keyway of the hollow shaft.
9. Screw in spigot ring [3] until it is firm against the shoulder.

4.3.1.2. Multi-turn actuator (with output drive type A): mount to valve

Figure 11: Assembly of output drive type A

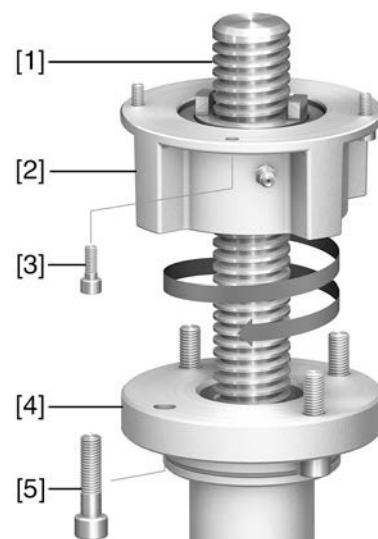

- [1] Valve stem
- [2] Output drive type A
- [3] Screws to actuator
- [4] Valve flange
- [5] Screws to output drive

1. If the output drive type A is already mounted to the multi-turn actuator: Loosen screws [3] and remove output drive type A [2].
2. Check if the flange of output drive type A matches the valve flange [4].
3. Apply a small quantity of grease to the valve stem [1].
4. Place output drive type A on valve stem and turn until it is flush on the valve flange.
5. Turn output drive type A until alignment of the fixing holes.
6. Screw in fastening screws [5], however do not completely tighten.
7. Fit multi-turn actuator on the valve stem so that the stem nut dogs engage into the output drive sleeve.
- ➡ The flanges are flush with each other if properly engaged.
8. Adjust multi-turn actuator until alignment of the fixing holes.
9. Fasten multi-turn actuator with screws [3].

10. Fasten screws [3] crosswise with a torque according to table.

Table 8:

Tightening torques for screws	
Threads	Tightening torque [Nm]
	Strength class A2-80/A4-80
M6	10
M8	24
M10	48
M12	82
M16	200
M20	392

11. Turn multi-turn actuator with handwheel in direction OPEN until valve flange and output drive A are firmly placed together.
12. Tighten fastening screws [5] between valve and output drive type A crosswise applying a torque according to table.

4.3.2. Output drive types B

- Application**
- For rotating, non-rising valve stem
 - Not capable of withstanding thrust

Design Connection between hollow shaft and valve or gearbox via output drive sleeve fixed to the hollow shaft of the multi-turn actuator via retaining ring.

When exchanging the output drive sleeve, later retrofitting to a different output drive type is possible

- Output drive type B: Output drive sleeve with bore according to DIN 3210
- Output drive types B1 – B4: Output drive sleeve with bore according to EN ISO 5210

Figure 12: Output drive type B

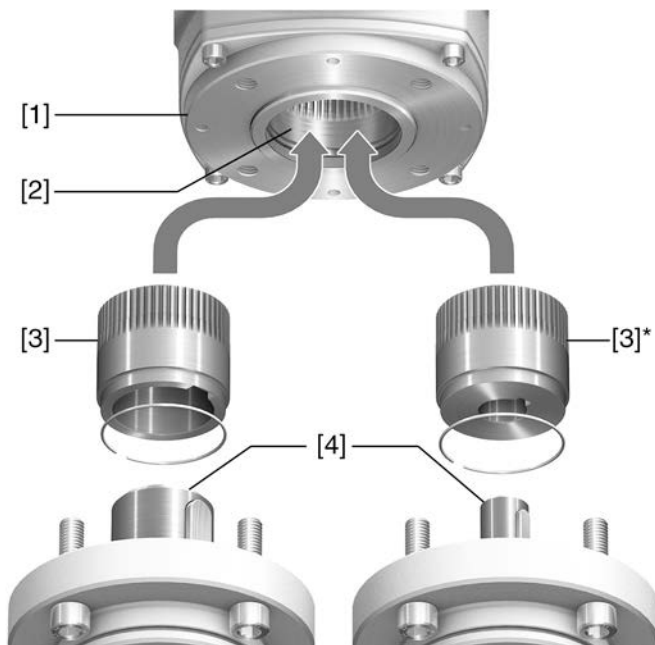

- [1] Flange multi-turn actuator (e.g. F07)
- [2] Hollow shaft
- [3] Output drive sleeve (illustration examples)
 [3] B/B1/B2 and [3]* B3/B4, respectively with bore and keyway
- [4] Gearbox/valve shaft with parallel key

Information Spigot at valve flanges should be loose fit.

4.3.2.1. Multi-turn actuator with output drive types B: mount to valve/gearbox

Figure 13: Mounting output drive types B

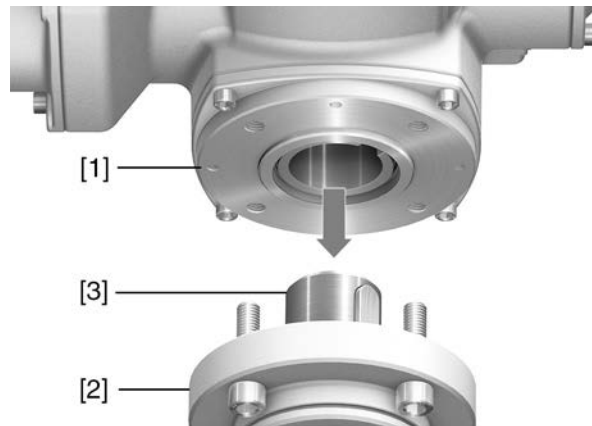

- [1] Multi-turn actuator
- [2] Valve/gearbox
- [3] Valve/gearbox shaft

1. Check if mounting flanges fit together.
2. Check if output drive of multi-turn actuator [1] matches the output drive of valve/gearbox or valve/gearbox valve shaft [2/3].
3. Apply a small quantity of grease to the valve or gearbox shaft [3].
4. Fit multi-turn actuator [1].

Information: Ensure that the spigot fits uniformly in the recess and that the mounting faces are in complete contact.

5. Fasten multi-turn actuator with screws according to table.

Information: We recommend applying liquid thread sealing material to the screws to avoid contact corrosion.

6. Fasten screws crosswise to a torque according to table.

Table 9:

Tightening torques for screws	
Threads	Tightening torque [Nm]
	Strength class A2-80/A4-80
M6	10
M8	24
M10	48
M12	82
M16	200
M20	392

4.4. Accessories for assembly

4.4.1. Stem protection tube for rising valve stem

Figure 14: Assembly of the stem protection tube

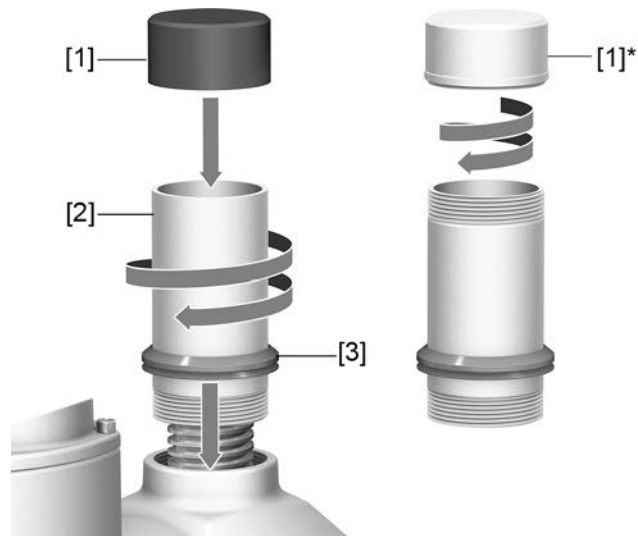

- [1] Protective cap for stem protection tube (fitted)
- [1]* Option: Protective cap made of steel (screwed)
- [2] Stem protection tube
- [3] V-seal

1. Seal all threads with hemp, Teflon tape, or thread sealing material.
2. Screw stem protection tube [2] into thread and tighten it firmly.

Information: For stem protection tubes made of two or more segments, all parts have to be thoroughly screwed together.

Figure 15: Protection tube made of segments with threaded sleeves (>900 mm)

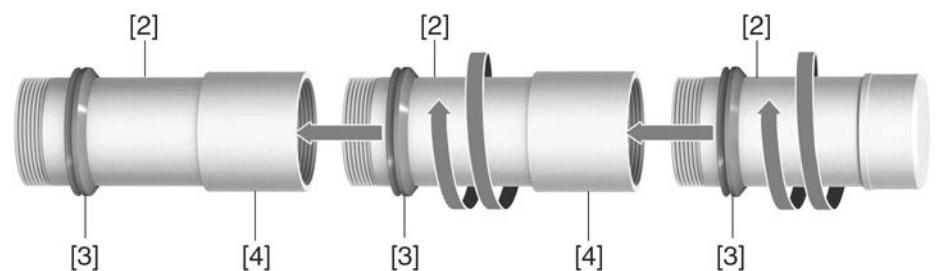

- [2] Segment of stem protection tube
- [3] V-seal
- [4] Threaded sleeve

3. Push down the sealing ring [3] onto the housing.
- Information:** For mounting segments, push down seals of segments down to the sleeve (connecting piece).
4. Check whether protective cap [1] for stem protection tube is available, in perfect condition and tightly placed on or screwed to the tube.

NOTICE

Risk of bending or oscillation of protection tubes exceeding a length of 2 m!

Risk of damage at stem and/or protection tube.

→ Secure protection tubes exceeding 2 m by an appropriate support.

4.5. Mounting positions of local controls

Figure 16: Mounting positions



The mounting position of the local controls is implemented according to the order. If, after mounting the actuator to the valve or the gearbox on site, the local controls are in an unfavourable position, the mounting position can be changed at a later date. Four mounting positions shifted by respectively 90° are possible (by maximum 180° into one direction).

4.5.1. Mounting positions: modify

DANGER

Hazardous voltage!

Risk of electric shock.

→ Disconnect device from the mains before opening.

NOTICE

Electrostatic discharge ESD!

Risk of damage to electronic components.

→ Earth both operators and devices.

1. Loosen screws and remove the local controls.
2. Check whether O-ring is in good condition, correctly insert O-ring.
3. Turn local controls into new position and re-place.

NOTICE

Cable damage due to twisting or pinching!

Risk of functional failures.

- Turn local controls by a maximum of 180°.
- Carefully assemble local controls to avoid pinching the cables.

4. Fasten screws evenly crosswise.

5. Electrical connection

5.1. Basic information



Danger due to incorrect electrical connection

Failure to observe this warning can result in death, serious injury, or property damage.

- The electrical connection must be carried out exclusively by suitably qualified personnel.
- Prior to connection, observe basic information contained in this chapter.
- After connection but prior to applying the voltage, observe the <Commissioning> and <Test run> chapters.

Wiring diagram/terminal plan

The pertaining wiring diagram/terminal plan (in German or English) is attached to the device in a weather-proof bag, together with these operation instructions. It can also be requested from AUMA (state order number, refer to name plate) or downloaded directly from the Internet (<http://www.auma.com>).

Permissible networks (supply networks)

Actuator controls (actuators) are suitable for use in TN and TT networks with directly earthed star point for mains voltage up to maximum 690 V AC. Use in IT networks for nominal voltages up to maximum 600 V AC are permissible. For IT network, a suitable, approved insulation monitor measuring the pulse code is required.

Current type, mains voltage, mains frequency

Type of current, mains voltage and mains frequency must match the data on the actuator controls and motor name plates. Also refer to chapter <Identification>/<Name plate>.

Figure 17: Motor name plate (example)

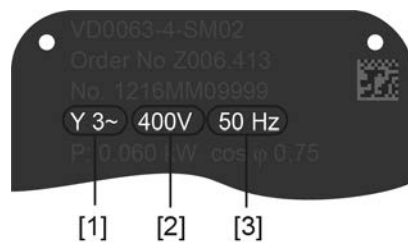

- [1] Type of current
- [2] Mains voltage
- [3] Mains frequency (for 3-phase and 1-phase AC motors)

External supply of the electronics

For external electronics supply with 24 V DC and simultaneous use of DC motors (24 V DC, 48 V DC, 60 V DC, 110 V DC, 220 V DC), the 24 V DC controls' voltage supply should be ensured via the XK25/26 terminals, separately from the power supply (U1, V1). In case of common supply using a single cable (links from U1, V1 with XK25/26, for 24 V DC only !!!), short-term excess or falling below the permissible voltage limits can be the consequence during switching (24 V DC +10 %/-10 %). Any possibly incoming operation commands are not executed outside the admissible limit values. The actuator controls briefly signal a fault condition.

Protection and sizing on site

For short-circuit protection and for disconnecting the actuator from the mains, fuses and disconnect switches have to be provided by the customer.

The current values for sizing the protection can be derived from the current consumption of the motor (refer to motor name plate) plus the current consumption of actuator controls.

We recommend adapting the switchgear sizing to the max. current (I_{max}) and selecting and setting the overcurrent protection device in compliance with the indications in the electrical data sheet.

Table 10:

Current consumption of actuator controls		
Mains voltage	Max. current consumption	
Permissible variation of the mains voltage	±10 %	–30 %
100 to 120 V AC	750 mA	1,000 mA
208 to 240 V AC	400 mA	750 mA
380 to 500 V AC	250 mA	400 mA
515 to 690 V AC	200 mA	400 mA

Table 11:

Maximum permissible protection		
Switchgear (switchgear with power class) ¹⁾	Rated power	max. protection
Reversing contactor A1	up to 1.5 kW	16 A (gL/gG)
Reversing contactor A2	up to 7.5 kW	32 A (gL/gG)
Reversing contactor A3	up to 15 kW	63 A (gL/gG)
Thyristor B1	up to 1.5 kW	16 A (g/R) I ² t<1,500A ² s
Thyristor B2	up to 3 kW	32 A (g/R) I ² t<1,500A ² s
Thyristor B3	up to 5.5 kW	63 A (g/R) I ² t<5,000A ² s

1) The AUMA power class (A1, B1, ...) is indicated on the actuator controls name plate

Consider the motor starting current (I_A) (refer to electrical data sheet) when selecting the circuit breaker. We recommend tripping characteristics D or K for circuit breakers in accordance with IEC 60947-2. For controls with thyristors, we recommend safety fuses instead of circuit breakers.

We recommend refraining from using residual current devices (RCD). However, if an RCD is used within the mains, the residual current device must be of type B.

For actuator controls equipped with a heating system and external electronics power supply, the fuses for the heating system have to be provided by the customer (refer to wiring diagram F4 ext.)

Table 12:

Fuse for heating system		
Designation in wiring diagram = F4 ext.		
External power supply	115 V AC	230 V AC
Fuse	2 A T	1 A T

If actuator controls are mounted separately from actuator (actuator controls on wall bracket): Consider length and cross section of connecting cable when defining the protection required.

Potential of customer connections

All input signals (control inputs) must be supplied with the same potential.
All output signals (status signals) must be supplied with the same potential.

Safety standards

Safety measures and safety equipment must comply with the respectively valid national on site specifications. All externally connected devices shall comply with the relevant safety standards for the place of installation.

Connecting cables

- We recommend using connecting cables and connecting terminals according to rated current (I_N) (refer to motor name plate or electrical data sheet).
- For device insulation, appropriate (voltage-proof) cables must be used. Specify cables for the highest occurring rated voltage.
- Use connecting cable with appropriate minimum rated temperature.
- For connecting cables exposed to UV radiation (outdoor installation), use UV resistant cables.
- For the connection of position transmitters, screened cables must be used.

Cable installation in accordance with EMC

Signal and fieldbus cables are susceptible to interference. Motor cables are interference sources.

- Lay cables being susceptible to interference or sources of interference at the highest possible distance from each other.
- The interference immunity of signal and fieldbus cables increases if the cables are laid close to the earth potential.
- If possible, avoid laying long cables and make sure that they are installed in areas being subject to low interference.
- Avoid parallel paths with little cable distance of cables being either susceptible to interference or interference sources.

5.2. S/SH electrical connection (AUMA plug/socket connector)

Figure 18: S and SH electrical connection

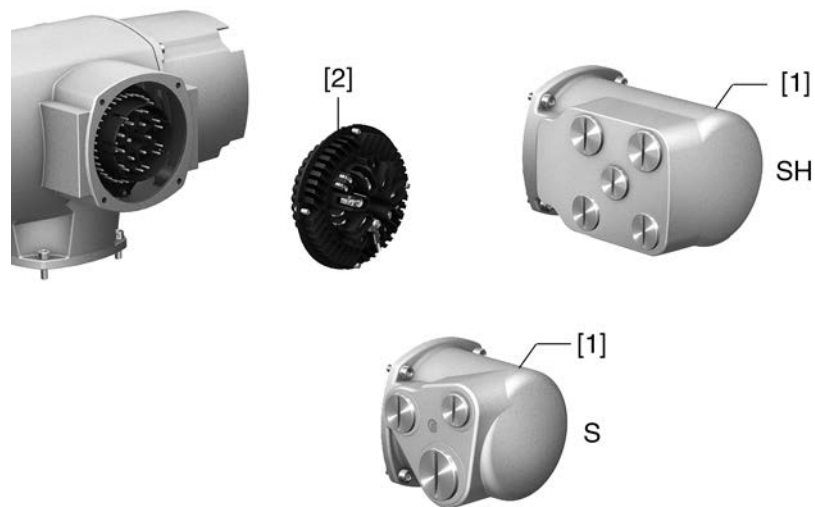

- [1] Cover
- [2] Socket carrier with screw-type terminals

Short description

Plug-in electrical connection with screw-type terminals for power and control contacts. Control contacts also available as crimp-type connection as an option.

S version (standard) with three cable entries. SH version (enlarged) with additional cable entries. For cable connection, remove the AUMA plug/socket connector and the socket carrier from cover.

Technical data

Table 13:

Electrical connection via AUMA plug/socket connector		
	Power contacts	Control contacts
No. of contacts max.	6 (3 equipped) + protective earth conductor (PE)	50 pins/sockets
Designation	U1, V1, W1, U2, V2, W2, PE	1 to 50
Connection voltage max.	750 V	250 V
Rated current max.	25 A	16 A
Type of customer connection	Screw connection	Screw connection, crimp-type (option)
Connection diameter max.	6 mm ² (flexible) 10 mm ² (solid)	2.5 mm ² (flexible or solid)

Information

For some special motors, the connection of the power terminals (U1, V1, W1, U2, V2, W2) is **not** performed via the AUMA plug/socket connector but via a terminal board directly at the motor.

5.2.1. Terminal compartment : open

Figure 19: Open terminal compartment

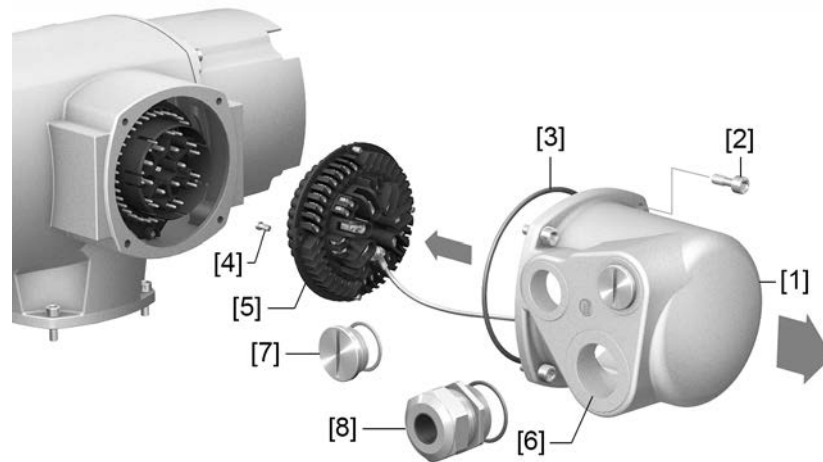

- [1] Cover (figure shows S version)
- [2] Screws for cover
- [3] O-ring
- [4] Screws for socket carrier
- [5] Socket carrier
- [6] Cable entry
- [7] Blanking plugs
- [8] Cable gland (not included in delivery)

DANGER**Hazardous voltage!***Risk of electric shock.*

→ Disconnect device from the mains before opening.

1. Loosen screws [2] and remove cover [1].
2. Loosen screws [4] and remove socket carrier [5] from cover [1].
3. Insert cable glands [8] suitable for connecting cables.
- The enclosure protection IP... stated on the name plate is only ensured if suitable cable glands are used.

Figure 20: Example: Name plate for enclosure protection IP68



4. Seal unused cable entries [6] with suitable blanking plugs [7].

5.2.2. Cable connection

Table 14:

Terminal cross sections and terminal tightening torques		
Designation	Terminal cross sections	Tightening torques
Power contacts (U1, V1, W1, U2, V2, W2)	1.0 – 6 mm ² (flexible) 1.5 – 10 mm ² (solid)	1.2 – 1.5 Nm
Protective earth connection ⊕ (PE)	1.0 – 6 mm ² (flexible) with ring lugs 1.5 – 10 mm ² (solid) with loops	1.2 – 2.2 Nm
Control contacts (1 to 50)	0.25 – 2.5 mm ² (flexible) 0.34 – 2.5 mm ² (solid)	0.5 – 0.7 Nm

1. Remove cable sheathing.
2. Insert the wires into the cable glands.
3. Fasten cable glands with the specified torque to ensure required enclosure protection.
4. Strip wires.
→ Controls approx. 6 mm, motor approx. 10 mm
5. For flexible cables: Use wire end sleeves according to DIN 46228.
6. Connect cables according to order-related wiring diagram.



In case of a fault: Hazardous voltage while protective earth conductor is NOT connected!

Risk of electric shock.

- Connect all protective earth conductors.
- Connect PE connection to external protective earth conductor of connecting cables.
- Start running the device only after having connected the protective earth conductor.

7. Tighten PE conductors firmly to PE connection using ring lugs (flexible cables) or loops (solid cables).

Figure 21: Protective earthing

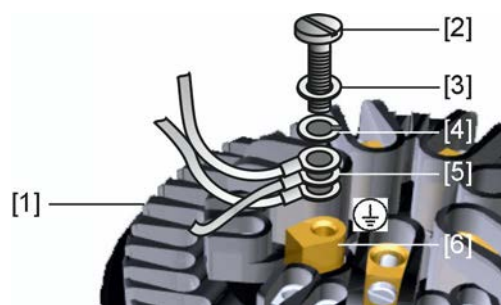

- [1] Socket carrier
- [2] Screw
- [3] Washer
- [4] Lock washer
- [5] Protective earth with ring lugs/loops
- [6] Protective earthing, symbol: ⊕

8. For shielded cables: Link the cable shield end via the cable gland to the housing (earthing).

5.2.3. Terminal compartment : close

Figure 22: Close terminal compartment

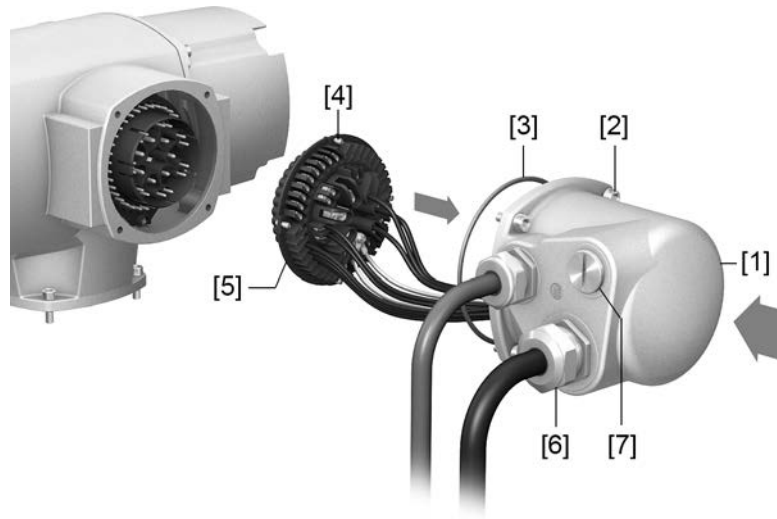

- [1] Cover (figure shows S version)
- [2] Screws for cover
- [3] O-ring
- [4] Screws for socket carrier
- [5] Socket carrier
- [6] Cable gland (not included in delivery)
- [7] Blanking plug

**Short-circuit due to pinching of cables!**

Risk of electric shock and functional failures.

→ Carefully fit socket carrier to avoid pinching the cables.

1. Insert the socket carrier [5] into the cover [1] and fasten with screws [4].
2. Clean sealing faces of cover [1] and housing.
3. Check whether O-ring [3] is in good condition, replace if damaged.
4. Apply a thin film of non-acidic grease (e.g. petroleum jelly) to the O-ring and insert it correctly.
5. Fit cover [1] and fasten screws [2] evenly crosswise.
6. Fasten cable glands and blanking plugs applying the specified torque to ensure the required enclosure protection.

5.3. Accessories for electrical connection

5.3.1. Controls mounted on wall bracket

Design Figure 23: Design principle with wall bracket

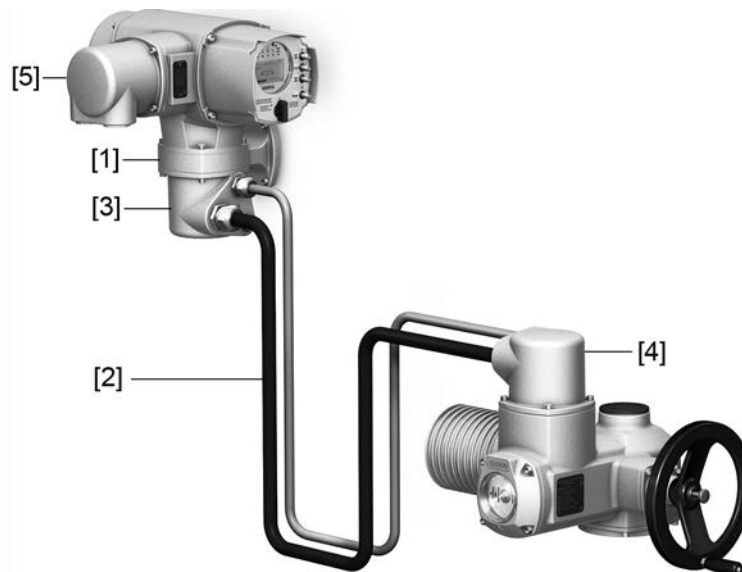

- [1] Wall bracket
- [2] Connecting cables
- [3] Electrical connection of wall bracket (XM)
- [4] Electrical connection of actuator (XA)
- [5] Electrical connection of controls (XK) - customer plug

Application The wall bracket allows separate mounting of controls and actuator.

Observe prior to connection

- If the actuator cannot be accessed.
- If the actuator is subjected to high temperatures.
- In case of heavy vibration of the valve.
- Permissible length of connecting cables: max. 100 m.
- We recommend: AUMA cable set LSW20.
- If the AUMA cable set is not used:
 - Use suitable flexible and screened connecting cables.
 - Use separate, CAN bus data cable for MWG of 120 Ohm character impedance (e.g. UNITRONIC BUS-FD P CAN UL/CSA - 2 x 2 x 0.5 mm², manufacturer: Lapp).
 - Data cable connection: XM2-XA2 = CAN L, XM3-XA3 = CAN H.
 - Voltage supply MWG: XM6-XA6 = GND, XM7-XA7 = + 24 V DC (refer to wiring diagram).
 - For the electrical connection at wall bracket [3], the terminals are made as crimp connections.
 - Use a suitable four indent crimp tool for crimping.
 - Cross sections for flexible wires:
 - Control cables: max. 0.75 to 1.5 mm²
 - Mains connection: max. 2.5 to 4 mm²
- When using connecting cables, e.g. of the heater, requiring direct wiring from the actuator to the XK customer connector (XA-XM-XK, refer to wiring diagram), these connecting cables must be subjected an insulation test in compliance with EN 50178. Connecting cables for MWG do not belong to this group. They may **not** be subjected to an insulation test.

5.3.2. Parking frame

Figure 24: Parking frame, example with S plug/socket connector and cover



Application Parking frame for safe storage of a disconnected plug or cover.

For protection against touching the bare contacts and against environmental influences.

5.3.3. DS intermediate frame for double sealing

Figure 25: Electrical connection with DS intermediate frame



[1] Electrical connection

[2] DS intermediate frame

Application When removing the electrical connection or due to leaky cable glands, there is a potential risk of ingress of dust and water into the housing. This is prevented effectively by inserting the double sealed intermediate frame [2] between the plug/socket connector [1] and the housing of the device. The enclosure protection of the device (IP68) will not be affected, even if the electrical connection [1] is removed.

5.3.4. External earth connection

Figure 26: Earth connection for multi-turn actuator



Application External earth connection (U-bracket) for connection to equipotential compensation.

Table 15:

Terminal cross sections and earth connection tightening torques		
Conductor type	Terminal cross sections	Tightening torques
Solid wire and stranded	2.5 mm ² to 6 mm ²	3 – 4 Nm
Fine stranded	1.5 mm ² to 4 mm ²	3 – 4 Nm

For fine stranded (flexible) wires, connection is made via cable lugs/ring terminals. When connecting two individual wires with a U-bracket, cross sections have to be identical.

6. Operation

6.1. Manual operation

For purposes of setting and commissioning, in case of motor or power failure, the actuator may be operated manually. Manual operation is engaged by an internal change-over mechanism.

6.1.1. Engage manual operation

NOTICE

Damage at the motor coupling due to faulty operation!

→ Engage manual operation only during motor standstill.

1. Press push button.

Figure 27: Engage manual operation

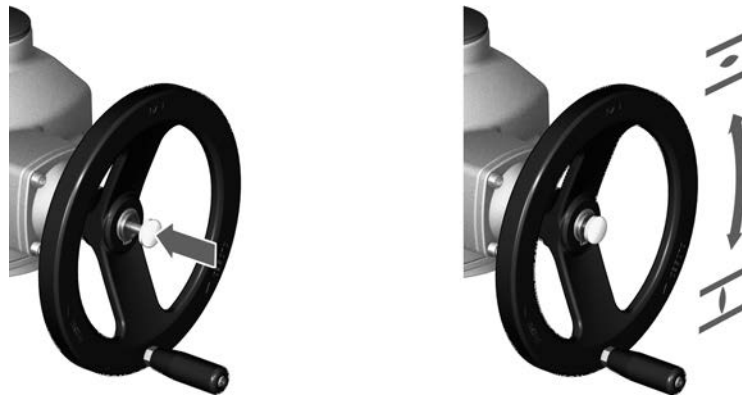

2. Turn handwheel in desired direction.

→ To close the valve, turn handwheel clockwise:

➔ Drive shaft (valve) turns clockwise in direction CLOSE.

Information

To protect the valve, an overload protection is available as option for manual operation. If the torque applied at the handwheel exceeds a certain value (refer to order-related technical data sheet), the shear pins will rupture and thus protect the valve from damage. The handwheel can no longer transmit the torque (= handwheel is spinning). Motor operation is still possible. In case of shear pin rupture due to overload, we recommend replacing the safety hub.

Figure 28: Handwheel without/with overload protection



[1] Handwheel without overload protection (standard)

[2] Handwheel with overload protection/safety hub (option)

6.1.2. Manual operation: disengage

Manual operation is automatically disengaged when motor is started again. The handwheel does not rotate during motor operation.

6.2. Motor operation

Perform all commissioning settings and the test run prior to motor operation.

NOTICE

Valve damage due to incorrect basic setting!

→ Prior to electrical operation of the actuator, the basic settings i.e. type of seating, torque and limit switching have to be completed.

6.2.1. Local actuator operation

Local actuator operation is performed using the local controls push buttons of actuator controls.

Figure 29: Local controls



- [1] Push button for operation command in direction OPEN
- [2] Push button STOP
- [3] Push button for operation command in direction CLOSE
- [4] Push button RESET
- [5] Selector switch

CAUTION

Hot surfaces, e.g. possibly caused by high ambient temperatures or strong direct sunlight!

Danger of burns

→ Check surface temperature and wear protective gloves, if required.

→ Set selector switch [5] to position **Local control** (LOCAL).

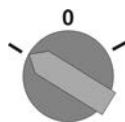

➔ The actuator can now be operated using the push buttons [1 – 3]:

- Run actuator in direction OPEN: Press push button [1]
- Stop actuator: Press push button STOP [2].
- Run actuator in direction CLOSE: Press push button [3]

Information

OPEN and CLOSE operation commands can be given either in push-to-run or in self-retaining operation mode. In self-retaining mode, the actuator runs to the defined end position after pressing the button, unless another command has been received beforehand. For further information, please refer to Manual (Operation and setting).

6.2.2. Actuator operation from remote



Risk of immediate actuator operation when switching on!

Risk of personal injuries or damage to the valve

- If the actuator starts unexpectedly: Immediately turn selector switch to position **0** (OFF).
- Check input signals and functions.

→ Set selector switch to position **Remote control** (REMOTE).

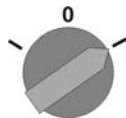

➔ Now, it is possible to operate the actuator via remote control, via operation commands (OPEN, STOP, CLOSE) or analogue setpoints (e.g. 0 – 20 mA).

Information For actuators equipped with a positioner, it is possible to change over between **OPEN - CLOSE control** (Remote OPEN-CLOSE) and **setpoint control** (Remote SET-POINT). Selection is made via MODE input, e.g. based on a 24 V DC signal (refer to wiring diagram).

6.3. Menu navigation via push buttons (for settings and indications)

Menu navigation for display and setting is made via the push buttons [1 – 4] of the local controls.

Set the selector switch [5] to position **0** (OFF) when navigating through the menu.

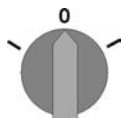

The bottom row of the display [6] serves as navigation support and explains which push buttons [1 – 4] are used for menu navigation.

Figure 30:

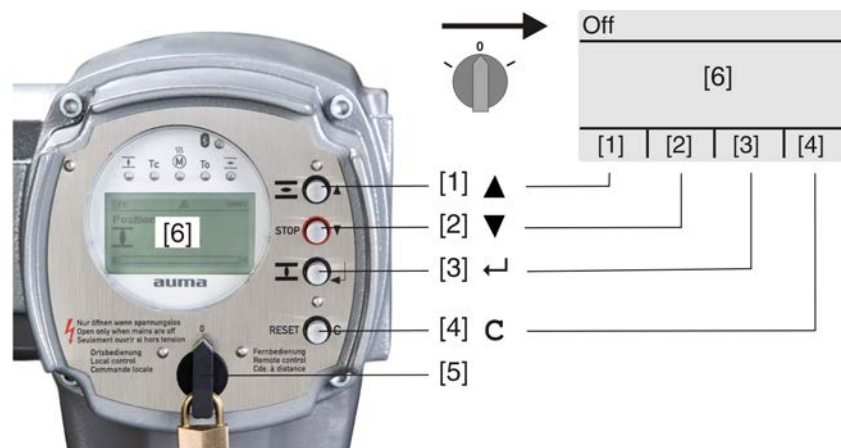

[1–4] Push buttons or navigation support

[5] Selector switch

[6] Display

Table 16: Important push button functions for menu navigation

Push buttons	Navigation support on display	Functions
[1] ▲	Up ▲	Change screen/selection Change values Enter figures from 0 to 9
[2] ▼	Down ▼	Change screen/selection Change values Enter figures from 0 to 9
[3] ↵	Ok	Confirm selection
	Save	Save
	Edit	Enter <Edit> menu
	Details	Display more details
[4] C	Setup	Enter Main menu
	Esc	Cancel process Return to previous display

- Backlight**
- The display is illuminated in white during normal operation. It is illuminated in red in case of a fault.
 - The screen illumination is brighter when operating a push button. If no push button is operated for 60 seconds, the display will become dim again.

6.3.1. Menu layout and navigation

Groups The indications on the display are divided into 3 groups:

Figure 31: Groups

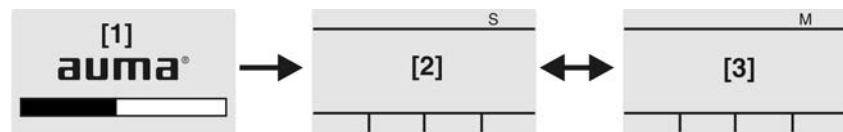

- [1] Startup menu
- [2] Status menu
- [3] Main menu

ID Status menu and main menu are marked with an ID.

Figure 32: Marking with ID

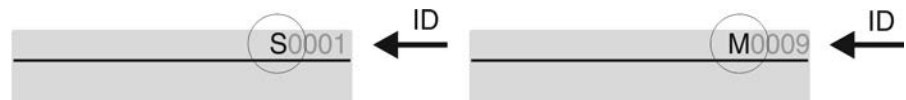

- S ID starts with S = status menu
- M ID starts with M = main menu

Group selection It is possible to select between status menu **S** and main menu **M**:

For this, set selector switch to **0** (OFF), hold down push button **C** for approx. 2 seconds until a screen containing the ID **M...** appears.

Figure 33: Select menu groups

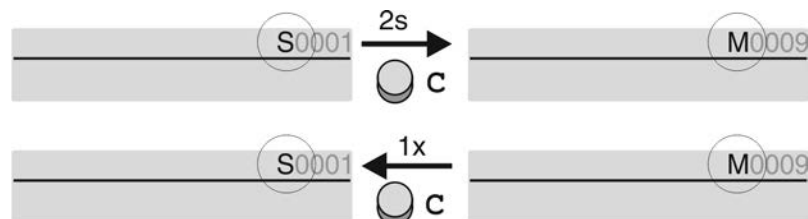

You return to the status menu if:

- the push buttons on the local controls have not been operated within 10 minutes
- or by briefly pressing **C**

Direct display via ID

When entering the ID within the main menu, screens can be displayed directly (without clicking through).

Figure 34: Direct display (example)

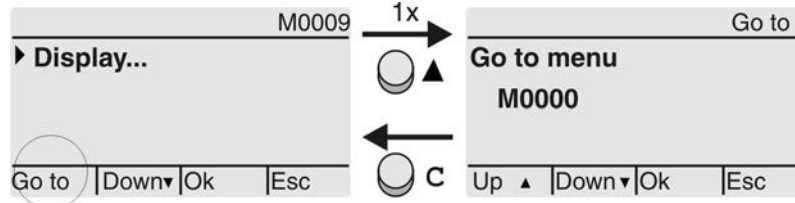

Display indicates in the bottom row: **Go to**

1. Press push button **▲ Go to**.
Display indicates: **Go to menu M0000**
2. Use push buttons **▲▼ Up ▲Down ▼** to select figures 0 to 9.
3. Press push button **↵ Ok** to confirm first digit.
4. Repeat steps 2 and 3 for all further digits.
5. To cancel the process: Press **C Esc**.

6.4. User level, password

User level The user level defines which menu items or parameters can be displayed or modified by the active user.

There are 6 different user levels. The user level is indicated in the top row:

Figure 35: User level display (example)

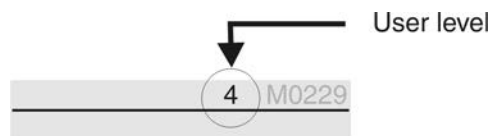

Password A password must be entered to allow parameter modification. The display indicates: **Password 0*****

A specific password is assigned to each user level and permits different actions.

Table 17:

User levels and authorisations	
Designation (user level)	Authorisation/password
Observer (1)	Verify settings No password required
Operator (2)	Change settings Default factory password: 0000
Maintenance (3)	Reserved for future extensions
Specialist (4)	Change device configuration e.g. type of seating, assignment of output contacts Default factory password: 0000
Service (5)	Service staff Change configuration settings
AUMA (6)	AUMA administrator

6.4.1. Password entry

1. Select desired menu and hold down push button **↵** for approx. 3 seconds.
➡ Display indicates the set user level, e.g **Observer (1)**
2. Press **▲ Up ▲** to select a higher user level and press **↵ Ok** to confirm.
➡ Display shows: **Password 0*****

3. Use push buttons ▲▼ Up ▲ Down ▼ to select figures 0 to 9.
 4. Confirm first digit of password via push button ←↵ Ok.
 5. Repeat steps 1 and 2 for all further digits.
- ➔ Having confirmed the last digit with ←↵ Ok, access to all parameters within one user level is possible if the password entry is correct.

6.4.2. Password change

Only the passwords of same or lower user level may be changed.

Example: The user is signed in as Specialist (4). This authorises him or her to modify the passwords between user levels (1) to (4).

M ▷ Device configuration M0053
 Service functions M0222
 Change passwords M0229

Menu point Service functions M0222 is only visible if user level has been set to Specialist (4) or higher.

- Select main menu**
1. Set selector switch to position 0 (OFF).

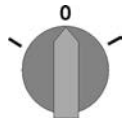

2. Press push button C Setup and hold it down for approx. 3 seconds.

➔ Display goes to main menu and indicates: ▶ Display...

Change passwords

3. Select parameter Change passwords either:
 - click via the menu M ▷ to parameter, or
 - via direct display: press ▲ and enter ID M0229
- Display indicates: ▶ Change passwords
- The user level is indicated in the top row (1 – 6), e.g.:



- For user level 1 (view only), passwords cannot be changed. To change passwords, you must change to a higher user level. For this, enter a password via a parameter.

4. For a user level between 2 and 6: Press push button ←↵ Ok.
- ➔ The display indicates the highest user level, e.g.: For user 4
5. Select user level via push buttons ▲▼ Up ▲ Down ▼ and confirm with ←↵ Ok.
- ➔ Display indicates: ▶ Change passwords Password 0***
6. Enter current password (→ enter password).
- ➔ Display indicates: ▶ Change passwords Password (new) 0***
7. Enter new password (→ enter password).
- ➔ Display indicates: ▶ Change passwords For user 4 (example)
8. Select next user level via push buttons ▲▼ Up ▲ Down ▼ or cancel the process via Esc.

6.5. Language in the display

The AUMATIC actuator controls display is multilingual.

6.5.1. Language change

M ▷ Display... M0009
 Language M0049

Select main menu

1. Set selector switch to position **0** (OFF).

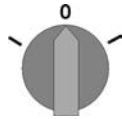

2. Press push button **C Setup** and hold it down for approx. 3 seconds.
➔ Display goes to main menu and indicates: ▶ **Display...**

Change language

3. Press **↵ Ok**.
➔ Display indicates: ▶ **Language**
4. Press **↵ Ok**.
➔ Display indicates the selected language, e.g.: ▶ **Deutsch**
5. The bottom row of the display indicates:
 - **Save** → continue with step 10
 - **Edit** → continue with step 6
6. Press **↵ Edit**.
➔ Display indicates: ▶ **Observer (1)**
7. Select user level via **▲▼ Up ▲ Down ▼** resulting in the following significations:
 - black triangle: ▶ = current setting
 - white triangle: ▷ = selection (not saved yet)
8. Press **↵ Ok**.
➔ Display indicates: **Password 0*****
9. Enter password (→ enter password).
➔ Display indicates: ▶ **Language** and **Save** (bottom row)

Language selection

10. Select new language via **▲▼ Up ▲ Down ▼** resulting in the following significations:
 - black triangle: ▶ = current setting
 - white triangle: ▷ = selection (not saved yet)
11. Confirm selection via **↵ Save**.
➔ The display changes to the new language. The new language selection is saved.

7. Indications

7.1. Indications during commissioning

LED test When switching on the power supply, all LEDs on the local controls illuminate for approx. 1 second. This optical feedback indicates that the voltage supply is connected to the controls and all LEDs are operable.

Figure 36: LED test

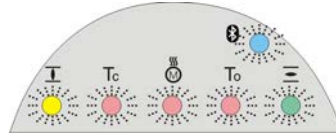

Language selection During the self-test, the language selection can be activated so that the selected language is immediately indicated in the display. For this, set selector switch to position **0** (OFF).

Activate language selection:

1. Display indicates in the bottom row: **Language selection menu? 'Reset'**
2. Press push button **RESET** and hold it down until the following text is displayed in the bottom line: **Language menu loading, please wait.**

Figure 37: Self-test

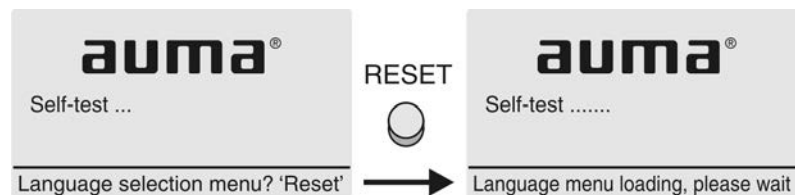

The language selection menu follows the startup menu.

Startup menu The current firmware version is displayed during the startup procedure:

Figure 38: Startup menu with firmware version: 04.00.00–xxxx

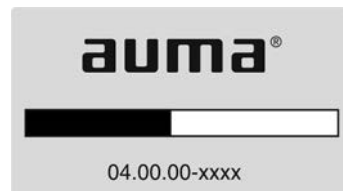

If the language selection feature has been activated during the self-test, the menu for selecting the display language will now be indicated. For further information on language setting, please refer to chapter <Language in the display>.

Figure 39: Language selection

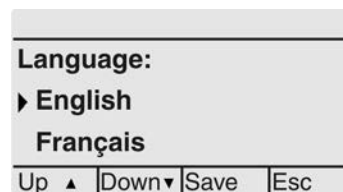

If no entry is made over a longer period of time (approx. 1 minute), the display automatically returns to the first status indication.

7.2. Indications in the display

Status bar The status bar (first row in the display) indicates the operation mode [1], the presence of an error [2] and the ID number [3] of the current display indication.

Figure 40: Information in the status bar (top)

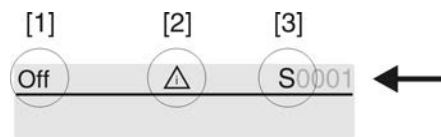

- [1] Operation mode
- [2] Error symbol (only for faults and warnings)
- [3] ID number: S = Status page

Navigation support

If further details or information are available with reference to the display, the following indications **Details** or **More** appear in the navigation support (bottom display row). Then, further information can be displayed via the **←** push button.

Figure 41: Navigation support (bottom)

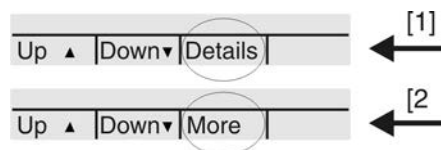

- [1] shows list with detailed indications
- [2] shows further available information

The navigation support (bottom row) is faded out after approx. 3 seconds. Press any push button (selector switch in position 0 (OFF)) to fade in the navigation support.

7.2.1. Feedback indications from actuator and valve

Display indications depend on the actuator version.

Valve position (S0001)

- **S0001** on the display indicates the valve position in % of the travel.
- The bar graph display appears after approx. 3 seconds.
- When issuing an operation command, an arrow indicates the direction (OPEN/CLOSE).

Figure 42: Valve position and direction of operation

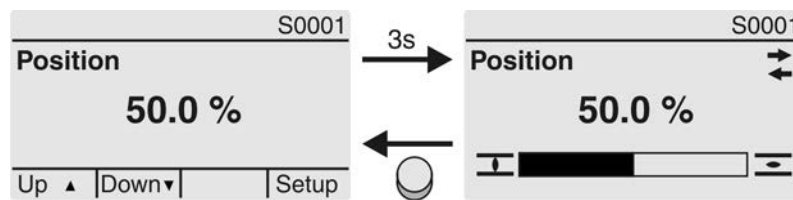

Reaching adjusted end positions is additionally indicated with symbols **┆** (CLOSED) and **≡** (OPEN).

Figure 43: End position CLOSED/OPEN reached

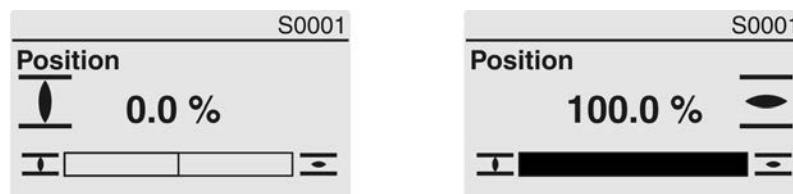

- 0% Actuator is in end position CLOSED
- 100% Actuator is in end position OPEN

Torque (S0002)

- **S0002** on the display indicates the torque applied at the actuator output.
- The bar graph display appears after approx. 3 seconds.

Figure 44: Torque

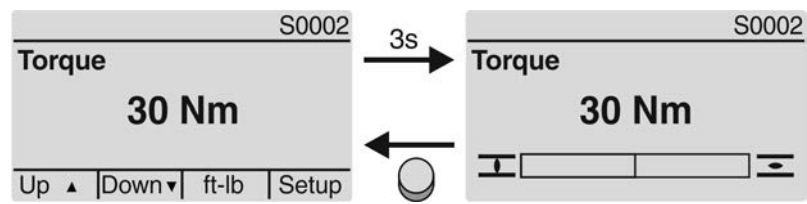

Select unit

The push button  allows to select the unit displayed (percent %, Newton metre Nm or "foot-pound" ft-lb)

Figure 45: Units of torque



Display in percent

100 % indication equals the max. torque indicated on the name plate of the actuator.

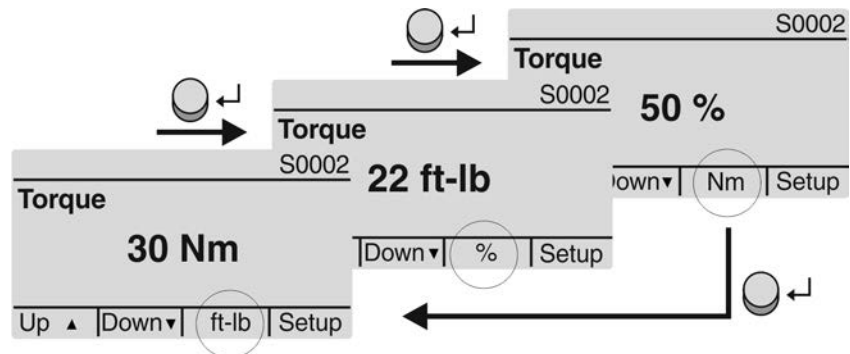
Example: SA 07.6 with 20 – 60 Nm.

- 100 % corresponds to 60 Nm of nominal torque.
- 50 % corresponds to 30 Nm of nominal torque.

Operation commands (S0003)

The display S0003 indicates:

- active operation commands, like e.g.: Operation in direction CLOSE or in direction OPEN
- the actual value E2 as bar graph indication and as value between 0 and 100 %.
- for setpoint control (positioner): setpoint E1
- for stepping mode or for intermediate positions with operation profile: pivot points and operation behaviour of pivot points

The navigation support (bottom row) is faded out after approx. 3 seconds and the axis/axes for pivot point display are shown.

OPEN - CLOSE control

Active operation commands (OPEN, CLOSE, ...) are shown above the bar graph display. The figure below shows the operation command in direction CLOSE.

Figure 46: Display for OPEN - CLOSE control

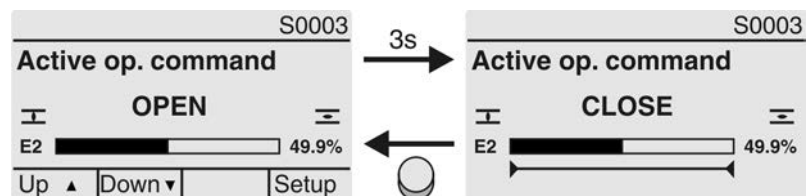

E2 Actual position value

Setpoint control

If the positioner is enabled and activated, the bar graph indication for E1 (position setpoint) is displayed.

The direction of the operation command is displayed by an arrow above the bar graph indication. The figure below shows the operation command in direction CLOSE.

Figure 47: Indication for setpoint control (positioner)

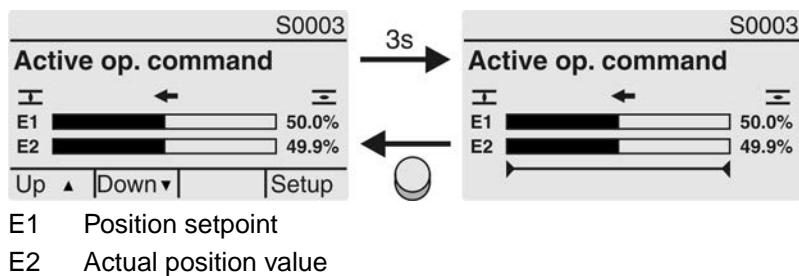

Pivot point axis

The pivot points and their operation behaviour (operation profile) are shown on the pivot point axis by means of symbols.

The symbols are only displayed if at least one of the following functions is activated:

Operation profile M0294

Timer CLOSE M0156

Timer OPEN M0206

Figure 48: Examples: on the left pivot points (intermediate positions); on the right stepping mode



Table 18: Symbols along the pivot point axis

Symbol	Pivot point (intermediate position) with operation profile	Stepping mode
	Pivot point without reaction	End of stepping mode
◀	Stop during operation in direction CLOSE	Start of stepping mode in direction CLOSE
▶	Stop during operation in direction OPEN	Start of stepping mode in direction OPEN
◆	Stop during operation in directions OPEN and CLOSE	–
◁	Pause for operation in direction CLOSE	–
▷	Pause for operation in direction OPEN	–
◇	Pause for operation in directions OPEN and CLOSE	–

Multiport valve positions (S0017)

In case of active multiport valve function, the display S0017 indicates a second bar graph with set positions (valve connections) above the actual position value E2. Positions (P1, P2, ...) are displayed with a black triangle ▼. Push buttons ▲▼ are used to select positions. Both positions and the actual position value E2 are displayed in degrees.

Figure 49: Status indication for multiport valve (example P4 = 180°)

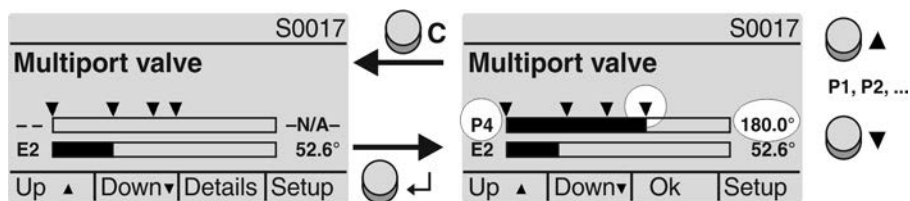

7.2.2. Status indications according to AUMA classification

These indications are available if the parameter **Diagnostic classific.** **M0539** is set to **AUMA**.

Warnings (S0005)

If a warning has occurred, the display shows **S0005**:

- the number of warnings occurred
- a blinking question mark after approx. 3 seconds

Figure 50: Warnings

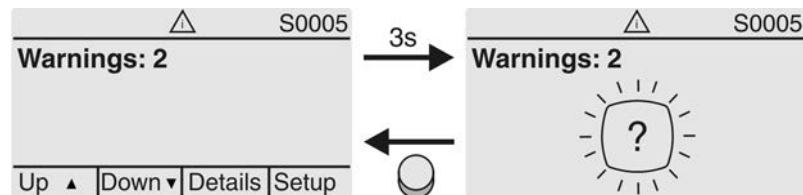

For further information, please also refer to <Corrective action>.

Not ready REMOTE (S0006)

The **S0006** display shows indications of the Not ready REMOTE group.

If such an indication has occurred, the display shows **S0006**:

- the number of indications occurred
- a blinking crossbar after approx. 3 seconds

Figure 51: Not ready REMOTE indications

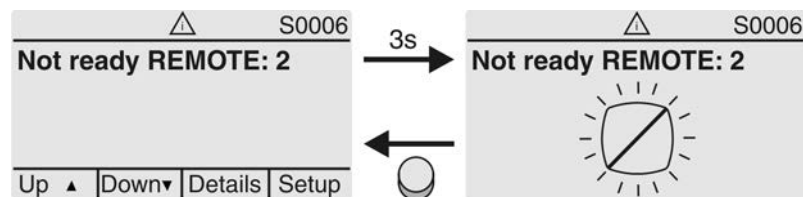

For further information, please also refer to <Corrective action>.

Fault (S0007)

If a fault has occurred, the display shows **S0007**:

- the number of faults occurred
- a blinking exclamation mark after approx. 3 seconds

Figure 52: Fault

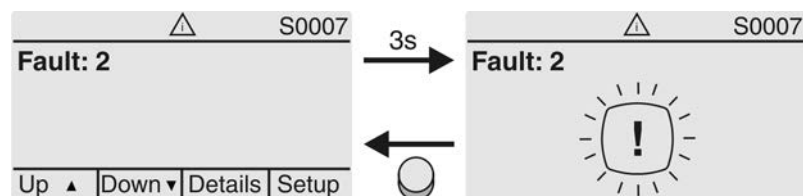

For further information, please also refer to <Corrective action>.

7.2.3. Status indications according to NAMUR recommendation

These indications are available, if the parameter **Diagnostic classific.** **M0539** is set to **NAMUR**.

Out of Specification (S0008)

The **S0008** indication shows out of specification indications according to NAMUR recommendation NE 107.

If such an indication has occurred, the display shows **S0008**:

- the number of indications occurred
- a blinking triangle with question mark after approx. 3 seconds

Figure 53: Out of specification

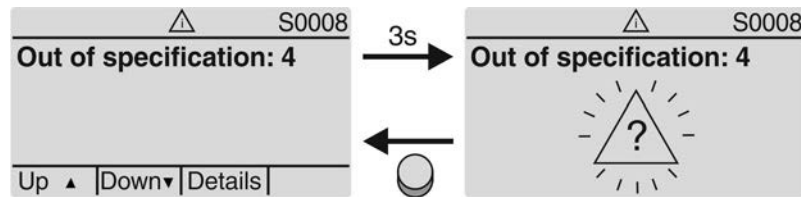

For further information, please also refer to <Corrective action>.

Function check (S0009)

The **S0009** indication shows function check indications according to NAMUR recommendation NE 107.

If an indication has occurred via the function check, the display shows **S0009**:

- the number of indications occurred
- a blinking triangle with a spanner after approx. 3 seconds

Figure 54: Function check

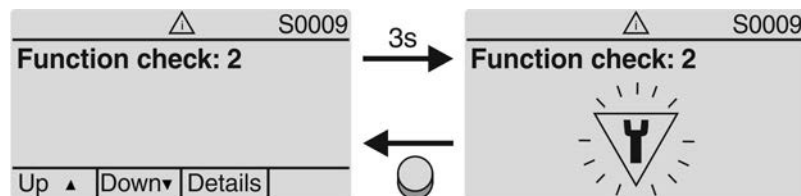

For further information, please also refer to <Corrective action>.

Maintenance required (S0010)

The **S0010** indication shows maintenance indications according to NAMUR recommendation NE 107.

If such an indication has occurred, the display shows **S0010**:

- the number of indications occurred
- a blinking square with an oilcan after approx. 3 seconds

Figure 55: Maintenance required

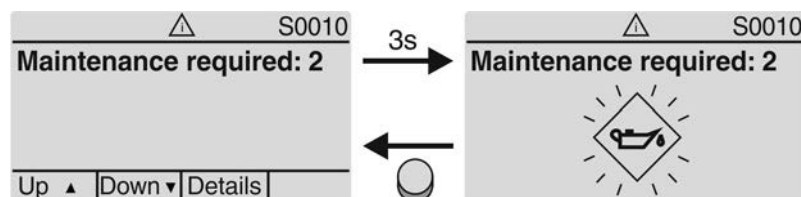

For further information, please also refer to <Corrective action>.

Failure (S0011)

The **S0011** indication shows the causes of the failure indication according to NAMUR recommendation NE 107.

If such an indication has occurred, the display shows **S0011**:

- the number of indications occurred
- a blinking circle with a cross after approx. 3 seconds

Figure 56: Failure

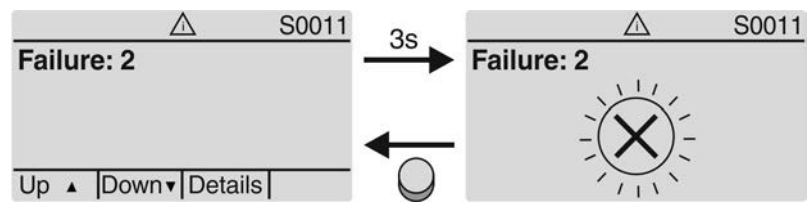

For further information, please also refer to <Corrective action>.

7.3. Indication lights of local controls

Figure 57: Arrangement and signification of indication lights



- [1] Marking with symbols (standard)
- [2] Marking with figures 1 – 6 (option)
- 1 End position CLOSED reached (blinking: operation in direction CLOSE)
- 2 Tc Torque fault CLOSE
- 3 Motor protection tripped
- 4 To Torque fault OPEN
- 5 End position OPEN reached (blinking: operation in direction OPEN)
- 6 Bluetooth connection

Modify indication light assignment (indications)

Different indications can be assigned to LEDs 1 – 5.

- M ▶ **Device configuration** M0053
 - Local controls** M0159
 - Indication light 1 (left) M0093
 - Indication light 2 M0094
 - Indication light 3 M0095
 - Indication light 4 M0096
 - Indicat. light 5 (right) M0097
 - Signal interm. pos. M0167

Default values (Europe):

- Indication light 1 (left) = End p. CLOSED, blink
- Indication light 2 = Torque fault CLOSE
- Indication light 3 = Thermal fault
- Indication light 4 = Torque fault OPEN
- Indicat. light 5 (right) = End p. OPEN, blink
- Signal interm. pos. = OPEN/CLOSED = Off

Further setting values:

Refer to Manual (Operation and setting).

7.4. Optional indications

7.4.1. Mechanical position indication (self-adjusting)

Figure 58: Mechanical position indicator



- [1] End position OPEN reached
[2] End position CLOSED reached

Characteristics

- Independent of power supply
- Used as running indication: Indicator disc (with arrow \Rightarrow) rotates during actuator operation and continuously indicates the valve position (For “clockwise closing version”, the arrow rotates in clockwise direction for operation in direction CLOSE)
- Indicates that end positions (OPEN/CLOSED) have been reached
Arrow \Rightarrow points to symbol —| (OPEN) or |— (CLOSED)
- Self-adjusting upon commissioning
(The cover does not have to be opened)

7.4.2. Mechanical position indication via indicator mark (not self-adjusting)

Figure 59: Mechanical position indicator



- [1] End position OPEN reached
[2] End position CLOSED reached
[3] Indicator mark at cover

Characteristics

- Independent of power supply
- Used as running indication: Indicator disc rotates during actuator operation and continuously indicates the valve position (For “clockwise closing version”, the symbols —| / |— rotate in counterclockwise direction for operation in direction CLOSE)
- Indicates that end positions (OPEN/CLOSED) have been reached
(Symbols —| (OPEN)/ |— (CLOSED) point to the indicator mark \blacktriangle at cover)

8. Signals (output signals)

8.1. Status signals via output contacts (digital outputs)

Characteristics Output contacts are used to send status signals (e.g. reaching the end positions, selector switch position, faults...) as binary signals to the control room.

Status signals only have two states: active or inactive. Active means that the conditions for the signal are fulfilled.

8.1.1. Assignment of outputs

The output contacts (outputs DOUT 1 – 12) can be assigned to various signals.

Required user level: **Specialist (4)** or higher.

M ▶ **Device configuration M0053**
I/O interface M0139
Digital outputs M0110
Signal DOUT 1 M0109

Default values:

Signal DOUT 1 = Fault
Signal DOUT 2 = End position CLOSED
Signal DOUT 3 = End position OPEN
Signal DOUT 4 = Selector sw. REMOTE
Signal DOUT 5 = Torque fault CLOSE
Signal DOUT 6 = Torque fault OPEN
Signal DOUT 7 = Thermal fault
Signal DOUT 8 = OPEN
Signal DOUT 9 = Limit switch CLOSED
Signal DOUT 10 = Limit switch OPEN
Signal DOUT 11 = Torque sw. CLOSED
Signal DOUT 12 = Torque sw. OPEN

8.1.2. Coding the outputs

The output signals **Coding DOUT 1 – Coding DOUT 12** can be set either to high active or low active.

- High active = output contact closed = signal active
- Low active = output contact open = signal active

Signal active means that the conditions for the signal are fulfilled.

Required user level: **Specialist (4)** or higher.

M ▶ **Device configuration M0053**
I/O interface M0139
Digital outputs M0110
Coding DOUT 1 M0102

Default values:

Coding DOUT 1 = Low active
Coding DOUT 2 – Coding DOUT 12 = High active

8.2. Analogue signals

Valve position Signal: E2 = 0/4 – 20 mA (galvanically isolated)

Designation in the wiring diagram:

ANOUT1 (position)

Torque feedback Signal: E6 = 0/4 – 20 mA (galvanically isolated)

Designation in the wiring diagram:

ANOUT2 (torque)

For further information on this topic, please refer to Manual (Operation and setting).

9. Commissioning (basic settings)

1. Set selector switch to position **0** (OFF).

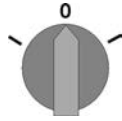

Information: The selector switch is not a mains switch. When positioned to **0** (OFF), the actuator cannot be operated. The controls' power supply is maintained.

2. Switch on the power supply.

Information: Observe heat-up time for ambient temperatures below $-30\text{ }^{\circ}\text{C}$.

3. Perform basic settings.

9.1. Type of seating: set

NOTICE

Valve damage due to incorrect setting!

- The type of seating must suit the valve.
- Only change the setting with the consent of the valve manufacturer.

- M ▶** Customer settings **M0041**
 Type of seating **M0012**
 End position CLOSED **M0086**
 End position OPEN **M0087**

Default value: Limit

Setting values:

Limit Seating in end positions via limit switching.

Torque Seating in end positions via torque switching.

- Select main menu** 1. Set selector switch to position **0** (OFF).

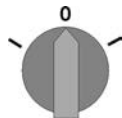

2. Press push button **C Setup** and hold it down for approx. 3 seconds.

➔ Display goes to main menu and indicates: ▶ **Display...**

- Select parameter** 3. Select parameter either:

- click via the menu **M ▶** to parameter, or
- via direct display: Press **▲** and enter ID **M0086** or **M0087**

➔ Display indicates: **End position CLOSED**

- CLOSE or OPEN** 4. Use **▲ ▼ Up ▲ Down ▼** to select:

- ▶ **End position CLOSED**
- ▶ **End position OPEN**

➔ The black triangle ▶ indicates the current selection.

5. Press **↵ Ok**.

➔ Display indicates the current setting: **Limit** or **Torque**

➔ The bottom row of the display indicates either:

- **Edit** → continue with step 6
- **Save** → continue with step 10

6. Press **↵ Edit**.

➔ Display indicates: ▶ **Specialist (4)**

- User login**
7. Use ▲▼ Up ▲ Down ▼ to select user:
 - Information:** Required user level: **Specialist (4)** or higher
 - ➔ The symbols have the following meaning:
 - black triangle: ▶ = current setting
 - white triangle: ▷ = selection (not saved yet)
 8. Press ← Ok.
 - ➔ Display indicates: **Password 0*****
 9. Enter password (→ enter password).
 - ➔ The screen indicates the pre-set type of seating (▶ **Limit** or ▶ **Torque**) by means of a black triangle ▶.
- Change settings**
10. Use ▲▼ Up ▲ Down ▼ to select new setting.
 - ➔ The symbols have the following meaning:
 - black triangle: ▶ = current setting
 - white triangle: ▷ = selection (not saved yet)
 11. Confirm selection via ← Save.
 - ➔ The setting for the type of seating is complete.
 12. Back to step 4 (CLOSED or OPEN): Press ← Esc .

9.2. Torque switching: set

Once the set torque is reached, the torque switches will be tripped (overload protection of the valve).

Information The torque switches may also trip during manual operation.

NOTICE

Valve damage due to excessive tripping torque limit setting!

- The tripping torque must suit the valve.
- Only change the setting with the consent of the valve manufacturer.

- M ▶
- Customer settings M0041
 - Torque switching M0013
 - Trip torque CLOSE M0088
 - Trip torque OPEN M0089

Default value: According to order data

Setting range: Torque range according to actuator name plate

- Select main menu**
1. Set selector switch to position **0** (OFF).

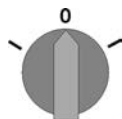

2. Press push button **C Setup** and hold it down for approx. 3 seconds.
 - ➔ Display goes to main menu and indicates: ▶ **Display...**

- Select parameter**
3. Select parameter either:
 - click via the menu M ▶ to parameter, or
 - via direct display: press ▲ and enter ID **M0088**.
 - ➔ Display indicates: **Trip torque CLOSE**

- CLOSE or OPEN**
4. Use ▲▼ Up ▲ Down ▼ to select:
 - ▶ **Trip torque CLOSE**
 - ▶ **Trip torque OPEN**
 - ➔ The black triangle ▶ indicates the current selection.

5. Press **↵** **Ok**.
 - ➔ Display shows the set value.
 - ➔ The bottom row indicates: **Edit Esc**
6. Press **↵** **Edit**.
 - ➔ Display indicates:
 - **Specialist (4)** → continue with step 7
 - in bottom row **Up ▲ Down ▼ Esc** → continue with step 11
- User login** 7. Use **▲ ▼ Up ▲ Down ▼** to select user:

Information: Required user level: **Specialist (4)** or higher.

 - ➔ The symbols have the following meanings:
 - black triangle: ▶ = current setting
 - white triangle: ▷ = selection (not saved yet)
8. Press **↵** **Ok**.
 - ➔ Display indicates: **Password 0*****
9. Enter password (→ enter password).
 - ➔ Display shows the set value.
 - ➔ The bottom row indicates: **Edit Esc**
- Change value** 10. Press **↵** **Edit**.
 11. Enter new value for tripping torque via **▲ ▼ Up ▲ Down ▼**.

Information: The adjustable torque range is shown in round brackets.
 12. Save new value via **↵** **Save**.
 - ➔ The tripping torque is set.
 13. Back to step 4 (CLOSED or OPEN): Press **↵** **Esc**.
- Information** The following fault signals are issued if the torque setting performed has been reached **in mid-travel**:
 - In the display of the local controls: Status indication **S0007 Fault = Torque fault OPEN** or **Torque fault CLOSE**

The fault has to be acknowledged before the operation can be resumed. The acknowledgement is made:

 1. either by an operation command in the opposite direction.
 - For **Torque fault OPEN**: Operation command in direction **CLOSE**
 - For **Torque fault CLOSE**: Operation command in direction **OPEN**
 2. or, in case the torque applied is lower than the preset tripping torque:
 - in selector switch position **Local control** (LOCAL) via push button **RESET**.
 - in selector switch position **Remote control** (REMOTE):
 - via a digital (I/O interface) with the Reset command if a digital input is configured for **RESET** signal.

9.3. Limit switching: set

NOTICE

Valve damage at valve/gearbox due to incorrect setting!

- When setting with motor operation: Stop actuator **prior** reaching end of travel (press STOP push button).
- Allow for overrun when selecting limit seating.

- M ▷** **Customer settings M0041**
Limit switching M0010
Set end pos. CLOSED? M0084
Set end pos. OPEN? M0085

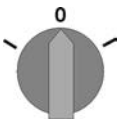
- Select main menu**
1. Set selector switch to position **0** (OFF).
- 
2. Press push button **C** and hold it down for approx. 3 seconds.
 - ➔ Display goes to main menu and indicates: ▶ **Display...**
- Select parameter**
3. Select parameter either:
 - click via the menu **M ▶** to parameter, or
 - via direct display: press **▲** and enter ID **M0084**.
 - ➔ Display indicates: **Set end pos.CLOSED?**
- CLOSED or OPEN**
4. Use **▲▼ Up ▲ Down ▼** to select:
 - ▶ **Set end pos.CLOSED? M0084**
 - ▶ **Set end pos. OPEN? M0085**
 - ➔ The black triangle ▶ indicates the current selection.
 5. Press **↵ Ok**.
 - ➔ The display indicates either:
 - **Set end pos.CLOSED? CMD0009** → continue with step 9
 - **Set end pos. OPEN? CMD0010** → continue with step 12
 - **Specialist (4)** → continue with step 6
- User login**
6. Use **▲▼ Up ▲ Down ▼** to select user:

Information: Required user level: **Specialist (4)** or higher

 - ➔ The symbols have the following meaning:
 - black triangle: ▶ = current setting
 - white triangle: ▷ = selection (not saved yet)
 7. Press **↵ Ok** to confirm to selected user.
 - ➔ Display indicates: **Password 0*****
 8. Enter password (→ enter password).
 - ➔ The display indicates either:
 - **Set end pos.CLOSED? CMD0009** → continue with step 9
 - **Set end pos. OPEN? CMD0010** → continue with step 12
- Set end position
CLOSED CMD0009**
9. Set again end position **CLOSED**:
 - 9.1 For large strokes: Set selector switch in position **Local control** (LOCAL) and operate actuator in motor operation via push button **┘** (CLOSE) in direction of the end position.

Information: Stop actuator **before** reaching end of travel (press **STOP** push button to avoid damage).
 - 9.2 Engage manual operation.
 - 9.3 Turn handwheel until valve is closed.
 - 9.4 Turn handwheel by approximately half a turn (overrun) in the opposite direction of end position.
 - 9.5 Set selector switch to position **0** (OFF).
 - ➔ Display indicates: **Set end pos.CLOSED? YesNo**

10. Press **↵ Yes** to accept new end position setting.
 - ➔ Display indicates: **End pos. CLOSED set!**
 - ➔ The left LED is illuminated (standard version) and thus indicates that the end position CLOSED setting is complete.

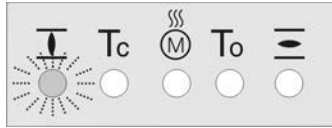

Set end position OPEN
CMD0010

11. Make selection:
 - **Edit** → back to step 9: Set end position CLOSED "once again"
 - **Esc** → back to step 4; either set end position OPEN or exit the menu.

12. Re-set end position OPEN:
 - 12.1 For large strokes: Set selector switch in position **Local control (LOCAL)** and operate actuator in motor operation via push button **☰ (OPEN)** in direction of the end position.

Information: Stop actuator **before** reaching end of travel (press **STOP** push button to avoid damage).

- 12.2 Engage manual operation.
- 12.3 Turn handwheel until valve is open.
- 12.4 Turn handwheel by approximately half a turn (overrun) in the opposite direction of end position.
- 12.5 Set selector switch to position **0 (OFF)**.

➔ Display indicates: **Set end pos. OPEN? Yes No**

13. Press **↵ Yes** to accept new end position setting.
 - ➔ Display indicates: **End pos. OPEN set!**
 - ➔ The right LED is illuminated (standard version) and thus indicates that the end position OPEN setting is complete.

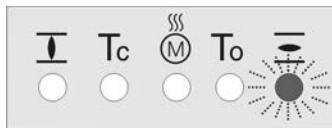

14. Make selection:
 - **Edit** → back to step 12: Set end position OPEN "once again"
 - **Esc** → back to step 4; either set end position CLOSED or exit the menu.

Information If an end position cannot be set: Check the type of control unit in actuator.

9.4. Test run

Only perform test run only once all settings previously described have been performed.

The direction of rotation can be checked at the position indicator if available. (Chapter <Direction of rotation at mechanical position indicator: check>)

The direction of rotation must be checked at the hollow shaft/stem if no mechanical position indicator is available. (Chapter <Direction of rotation at hollow shaft/stem: check>)

9.4.1. Direction of rotation at mechanical position indicator: check**NOTICE****Valve damage due to incorrect direction of rotation!**

- If the direction of rotation is wrong, switch off immediately (press STOP).
- Eliminate cause, i.e. correct phase sequence for cable set wall bracket.
- Repeat test run.

Information Switch off before reaching the end position.

1. Move actuator manually to intermediate position or to sufficient distance from end position.
2. Switch on actuator in direction CLOSE and observe the direction of rotation on the mechanical position indication:

→ **For self-adjusting mechanical position indication:**

- The direction of rotation is correct if the actuator operates in direction **CLOSE** and arrow \Rightarrow turns **clockwise** in direction CLOSE (symbol $\overline{\text{I}}$).

Figure 60: Direction of rotation \Rightarrow (for “clockwise closing” version”)



→ **For mechanical position indication via indicator mark: (not self-adjusting)**

- The direction of rotation is correct if the actuator operation in direction **CLOSE** and the symbols $\overline{\text{I}}$ turn **counterclockwise**:

Figure 61: Direction of rotation $\overline{\text{I}}$ (for “clockwise closing” version”)



9.4.2. Direction of rotation at hollow shaft/stem: check

NOTICE

Valve damage due to incorrect direction of rotation!

- If the direction of rotation is wrong, switch off immediately (press STOP).
- Eliminate cause, i.e. correct phase sequence for cable set wall bracket.
- Repeat test run.

Information

Switch off before reaching the end position.

1. Move actuator manually to intermediate position or to sufficient distance from end position.
2. Unscrew threaded plug [1] and seal [2] or protective cap for stem protection tube [4].
3. Switch on actuator in direction CLOSE and observe direction of rotation at hollow shaft [3] or stem [5]:

➔ The direction of rotation is correct if the actuator moves in direction **CLOSE** and the hollow shaft in **clockwise** direction, or the stem moves downward.

Figure 62: Hollow shaft/stem movement (for “clockwise closing”)

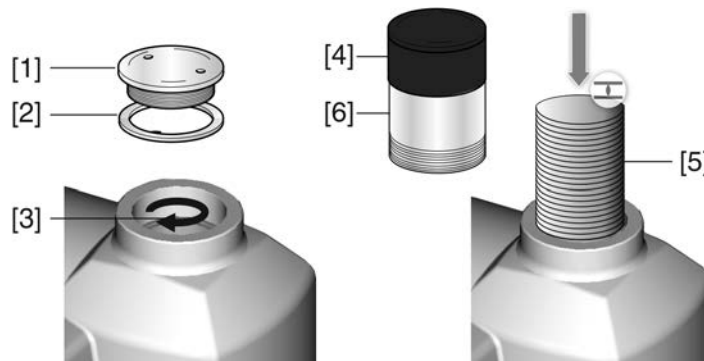

- [1] Threaded plug
- [2] Seal
- [3] Hollow shaft
- [4] Protective cap for stem protection tube
- [5] Stem
- [6] Stem protection tube

4. Correctly fit/screw on threaded plug [1] and seal [2] or protective cap for stem protection tube [4], fasten thread.

9.4.3. Limit switching: check

1. Set selector switch to position **Local control** (LOCAL).

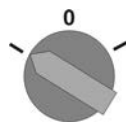

2. Operate actuator using push buttons OPEN, STOP, CLOSE.
 - The limit switching is set correctly if (default indication):
 - the yellow indication light/LED1 is illuminated in end position CLOSED
 - the green indication light/LED5 is illuminated in end position OPEN
 - the indication lights go out after travelling into opposite direction.
 - The limit switching is set incorrectly if:
 - the actuator comes to a standstill before reaching the end position
 - one of the red indication lights/LEDs is illuminated (torque fault)
 - the status indication **S0007** in the display signals a fault.
3. If the end position setting is incorrect: Reset limit switching.

10. Commissioning (settings/options in the actuator)

For actuators without mechanical position indicator (cover without indicator glass), no settings are required within the actuator when commissioning.

When equipped with the self-adjusting mechanical position indicator [A], the position indicator automatically adjusts upon the initial operation (e.g. from CLOSED to OPEN). This self-adjustment is generally performed when setting the limit switches (approaching the end positions). Manual setting and consequently opening the switch compartment is not necessary when commissioning.

In case the mechanical position indicator integrated within the actuator is NOT self-adjusting [B], the switch compartment must be opened for mechanical position indication adjustment when commissioning.

Figure 63: Mechanical position indicators

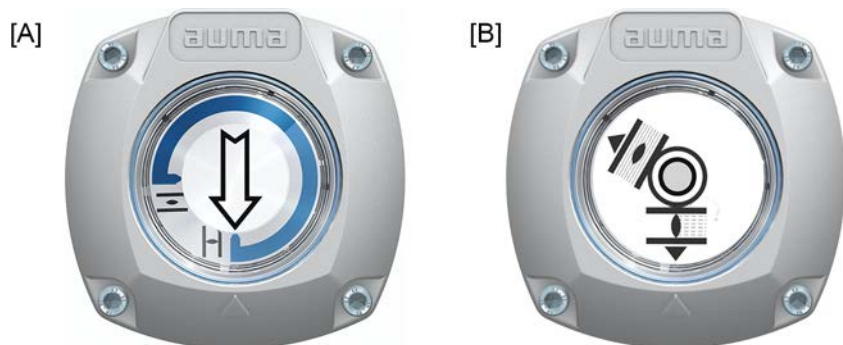

[A] Mechanical position indicator (self-adjusting)

[B] Mechanical position indicator via indicator mark (not self-adjusting)

10.1. Switch compartment: open/close

Figure 64: Open/close switch compartment



[A] Mechanical position indication (self-adjusting)

[B] Mechanical position indication via indicator mark

- | | |
|--------------|---|
| Open | 1. Loosen screws [2] and remove cover [1] from the switch compartment. |
| Close | 2. Clean sealing faces of housing and cover. |
| | 3. Check whether O-ring [3] is in good condition, replace if damaged. |
| | 4. Apply a thin film of non-acidic grease (e.g. petroleum jelly) to the O-ring and insert it correctly. |
| | 5. Place cover [1] on switch compartment. |
| | 6. Fasten screws [2] evenly crosswise. |

10.2. Mechanical position indicator (self-adjusting)

Figure 65: Mechanical position indicator (self-adjusting)



The self-adjusting mechanical position indicator shows the valve position by means of an arrow \Rightarrow . When correctly set, the arrow points to symbol \equiv (OPEN) or \perp (CLOSED) in the end positions.

Information The position indications is housed in the actuator switch compartment. Opening the switch compartment for manual setting is only necessary if the gear stage setting must be modified or if the factory settings of predefined end position CLOSED (or OPEN) must be adapted when commissioning.

10.2.1. Mechanical position indicator: set

1. Move valve to end position CLOSED.
2. Push both lower discs with the symbols \equiv (OPEN) and \perp (CLOSED) towards each other. The disc with the arrow is thereby \Rightarrow is driven:

Figure 66: Setting position in CLOSED

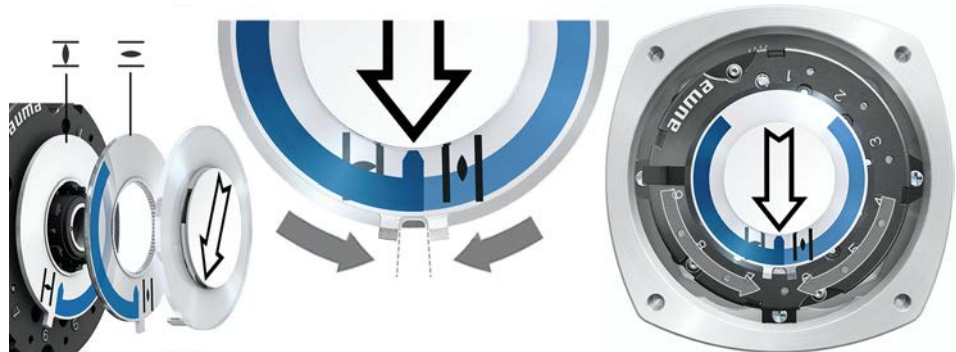

3. Move actuator to end position OPEN.
- ➔ The arrow \Rightarrow rotates in direction OPEN driving the indicator disc with symbol \equiv (OPEN) until the actuator stops in position OPEN.

Figure 67: Operation in direction OPEN (left) and position OPEN (right)



4. Check settings:

- ➔ The setting of the mechanical position indicator is correct, if the angle between the symbols $\overline{\text{O}}$ (OPEN) and $\overline{\text{I}}$ (CLOSED) ranges between approx. 120° and 280°.
- ➔ If all three discs are turned at the same time, the indicator can be shifted in steps of 15°. Individual shifts of 5° are possible.
- ➔ If the indicator is rotated too far (more than 280°) or the angle too small (below 120°), adapt the turns/stroke of the actuator. Refer to <Gear stage of the reduction gearing: test/set>.

10.2.2. Gear stage of the reduction gearing: test/set

The test/setting is only required if the mechanical position indicator cannot be correctly set.

1. Refer to table and check if turns/stroke correspond to the setting of the reduction gearing (stages 1– 9).

Table 19:

Turns of actuator per valve stroke and suitable reduction gearing setting		
for 1 – 500 turns/stroke [exceeding – to]	for 10 – 5,000 turns/stroke [exceeding – to]	Reduction gearing Stage
1.0 – 1.9	10 – 19	1
1.9 – 3.7	19 – 37	2
3.7 – 7.9	37 – 79	3
7.9 – 15.0	79 – 150	4
15.0 – 31.5	150 – 315	5
31.5 – 60.0	315 – 600	6
60.0 – 126	600 – 1,260	7
126 – 240	1,250 – 2,500	8
240 – 500	2,500 – 5,000	9

2. To modify settings, lift the lever at the reduction gearing and engage at the selected stage.

Figure 68: Set reduction gearing



10.3. Mechanical position indication via indicator mark (not self-adjusting)

Figure 69: Mechanical position indication via indicator mark



The mechanical position indicator shows the valve position via two indicator discs with symbols $\overline{\text{O}}$ (OPEN) and $\overline{\text{C}}$ (CLOSED). When correctly set, the symbols OPEN/CLOSED point to the indicator mark \blacktriangle at the cover in the end positions.

Setting elements

The position indications is housed in the actuator switch compartment. The switch compartment must be opened to perform any settings. Refer to <Switch compartment: open/close>.

10.3.1. Mechanical position indicator: set

1. Move valve to end position CLOSED.
2. Turn lower indicator disc until symbol $\overline{\text{C}}$ (CLOSED) is in alignment with the \blacktriangle mark on the cover.



3. Move actuator to end position OPEN.
4. Hold lower indicator disc in position and turn upper disc with symbol $\overline{\text{O}}$ (OPEN) until it is in alignment with the \blacktriangle mark on the cover.



5. Move valve to end position CLOSED again.
6. Check settings:
If the symbol $\overline{\text{C}}$ (CLOSED) is no longer in alignment with \blacktriangle mark on the cover:
 - 6.1 Repeat setting procedure.
 - 6.2 Test/set gear stage of the reduction gearing.

10.3.2. Gear stage of the reduction gearing: test/set

This test/setting is only required if the turns/stroke of the actuator were changed at a later date. The control unit may possibly have to be exchanged:

Information

The adjustable stroke range is indicated on the order data sheet (e.g. "1 – 500 turns/stroke").

1. Pull off indicator disc using a spanner as lever if required.



2. Refer to table and check if turns/stroke of the actuator correspond to the setting of the reduction gearing (stages 1– 9).
If the setting is **not correct**: continue with step 3.
If the setting is correct: continue with step 6.

MS5.2 control unit (1 to 500 turns per stroke)	
Turns/stroke above – to	Gear stage
1.0 – 1.9	1
1.9 – 3.9	2
3.9 – 7.8	3
7.8 – 15.6	4
15.6 – 31.5	5
31.5 – 62.5	6
62.5 – 125	7
125 – 250	8
250 – 500	9

MS50.2 control unit (10 to 5,000 turns per stroke)	
Turns/stroke above – to	Gear stage
10.0 – 19.5	1
19.5 – 39.0	2
39.0 – 78.0	3
78 – 156	4
156 – 315	5
315 – 625	6
625 – 1,250	7
1,250 – 2,500	8
2,500 – 5,000	9

3. Loosen screw [1].
4. Set crown wheel [2] to desired level according to table.
5. Tighten screw [1].
6. Place indicator disc on shaft.
7. Set mechanical position indicator.

Figure 70: Control unit with reduction gearing

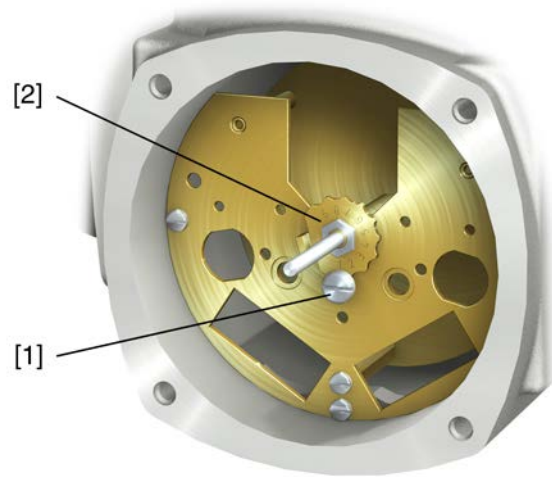

- [1] Screw
- [2] Crown wheel

11. Corrective action

11.1. Faults during operation/commissioning

Table 20:

Faults during operation/commissioning		
Fault	Description/cause	Remedy
Mechanical position indicator cannot be set.	Reduction gearing is not suitable for turns/stroke of the actuator.	Set gear stage of the reduction gearing. The control unit might have to be exchanged.
In spite of correct setting of limit switching, actuator operated into the valve end position.	The overrun was not considered when setting the limit switching. The overrun is generated by the inertia of both the actuator and the valve and the delay time of the actuator controls.	<ul style="list-style-type: none"> Determine overrun: Overrun = travel covered from switching off until complete standstill. Set limit switching again considering the overrun. (Turn handwheel back by the amount of the overrun)
Handwheel rotates on the shaft without transmitting torque.	Actuator in version with overload protection for manual operation: Shear pin rupture due to excessive torque at handwheel.	Dismount handwheel. Replace overload protection and remount handwheel.

11.2. Fault indications and warning indications

Faults interrupt or prevent the electrical actuator operation. In the event of a fault, the display backlight is red.

Warnings have no influence on the electrical actuator operation. They only serve for information purposes. The display remains white.

Collective signals include further indications. They can be displayed via the  **Details** push button. The display remains white.

Table 21:







Faults and warnings via status indications in the display		
Indication on display	Description/cause	Remedy
S0001	Instead of the valve position, a status text is displayed.	For a description of the status texts, refer to Manual (Operation and setting).
S0005 Warnings	Collective signal 02: Indicates the number of active warnings.	For indicated value > 0: Press push button  De- tails . For details, refer to <Warnings and Out of specification> table.
S0006 Not ready REMOTE	Collective signal 04: Indicates the number of active signals.	For indicated value > 0: Press push button  De- tails . For details, refer to <Not ready REMOTE and Function check> table.
S0007 Fault	Collective signal 03: Indicates the number of active faults. The actuator cannot be operated.	For indicated value > 0: Press push button  Details to display a list of detailed indications. For details, refer to <Faults and Failure> table.
S0008 Out of specification	Collective signal 07: Indication according to NAMUR recommendation NE 107 Actuator is operated outside the normal operation conditions.	For indicated value > 0: Press push button  De- tails . For details, refer to <Warnings and Out of specification> table.
S0009 Function check	Collective signal 08: Indication according to NAMUR recommendation NE 107 The actuator is being worked on; output signals are temporarily invalid.	For indicated value > 0: Press push button  De- tails . For details, refer to <Not ready REMOTE and Function check> table.
S0010 Maintenance required	Collective signal 09: Indication according to NAMUR recommendation NE 107 Recommendation to perform maintenance.	For indicated value > 0: Press push button  Details to display a list of detailed indications.
S0011 Failure	Collective signal 10: Indication according to NAMUR recommendation NE 107 Actuator function failure, output signals are invalid	For indicated value > 0: Press push button  Details to display a list of detailed indications. For details, refer to <Faults and Failure> table.

Table 22:

Warnings and Out of specification		
Indication on display	Description/cause	Remedy
Config. warning	Collective signal 06: Possible cause: Configuration setting is incorrect. The device can still be operated with restrictions.	Press push button  Details to display a list of individual indications. For a description of the individual signals, refer to Manual (Operation and setting).
Internal warning	Collective signal 15: Device warnings The device can still be operated with restrictions.	Press push button  Details to display a list of individual indications. For a description of the individual signals, refer to Manual (Operation and setting).
24 V DC external	The external 24 V DC voltage supply of the controls has exceeded the power supply limits.	Check 24 V DC voltage supply.
Wrn op.mode run time	Warning on time max. running time/h exceeded	<ul style="list-style-type: none"> • Check modulating behaviour of actuator. • Check parameter Perm. run time M0356, re-set if required.
Wrn op.mode starts	Warning on time max. number of motor starts (starts) exceeded	<ul style="list-style-type: none"> • Check modulating behaviour of actuator. • Check parameter Permissible starts M0357, re-set if required.
Failure behav. active	The failure behaviour is active since all required setpoints and actual values are incorrect.	Verify signals: <ul style="list-style-type: none"> • Setpoint E1 • Actual value E2 • Actual process value E4
Wrn input AIN 1	Warning: Loss of signal analogue input 1	Check wiring.
Wrn input AIN 2	Warning: Loss of signal analogue input 2	Check wiring.
Wrn setpoint position	Warning: Loss of signal setpoint position Possible causes: For an adjusted setpoint range of e.g. 4 – 20 mA, the input signal is 0 (signal loss). For a setpoint range of 0 – 20 mA , monitoring is not possible.	Check setpoint signal.
Op. time warning	The set time (parameter Perm.op. time, manual M0570) has been exceeded. The preset operating time is exceeded for a complete travel from end position OPEN to end position CLOSED.	The warning indications are automatically cleared once a new operation command is executed. <ul style="list-style-type: none"> • Check valve. • Check parameter Perm.op. time, manual M0570.
Wrn controls temp.	Temperature within controls housing too high.	Measure/reduce ambient temperature.
Time not set	Real time clock has not yet been set.	Set time.
RTC voltage	Voltage of the RTC button cell is too low.	Replace button cell.
PVST fault	Partial Valve Stroke Test (PVST) could not be successfully completed.	Check actuator (PVST settings).
PVST abort	Partial Valve Stroke Test (PVST) was aborted or could not be started.	Perform RESET or restart PVST.
Wrn no reaction	No actuator reaction to operation commands within the set reaction time.	<ul style="list-style-type: none"> • Check movement at actuator. • Check parameter Reaction time M0634.
Wrn FOC ¹⁾	Optical receiving signal (channel 1) incorrect (no or insufficient Rx receive level) or RS-485 format error (incorrect bit(s))	Check/repair FO cables.
Wrn FO cable budget ¹⁾	Warning: FO cable system reserve reached (critical or permissible Rx receive level)	Check/repair FO cables.
Wrn FOC connection ¹⁾	Warning FO cable connection is not available.	Fit FO cable connection.
Torque wrn OPEN	Limit value for torque warning in direction OPEN exceeded.	Check parameter Wrn torque OPEN M0768 , re-set if required.
Torque wrn CLOSE	Limit value for torque warning in direction CLOSE exceeded.	Check parameter Wrn torque CLOSE M0769 , re-set if required.
SIL fault ²⁾	SIL sub-assembly fault has occurred.	Refer to separate Manual Functional Safety.

Warnings and Out of specification		
Indication on display	Description/cause	Remedy
PVST required	Execution of PVST (Partial Valve Stroke Tests) is required.	
Maintenance required	Maintenance is required.	
FQM fail safe fault ³⁾	FQM fault	Checking and fault remedy are required. Refer to FQM operation instructions.

- 1) For actuator controls with FOC connection
- 2) For actuators controls in SIL version
- 3) For actuators with fail safe unit

Table 23:

Faults and Failure		
Indication on display	Description/cause	Remedy
Configuration error	Collective signal 11: Configuration error has occurred.	Press push button Details to display a list of individual indications. For a description of the individual signals, refer to Manual (Operation and setting).
Config. error REMOTE	Collective signal 22: Configuration error has occurred.	Press push button Details to display a list of individual indications. For a description of the individual signals, refer to Manual (Operation and setting).
Internal error	Collective signal 14: Internal error has occurred.	AUMA service Press push button Details to display a list of individual indications. For a description of the individual signals, refer to Manual (Operation and setting).
Torque fault CLOSE	Torque fault in direction CLOSE	Perform one of the following measures: <ul style="list-style-type: none"> • Issue operation command in direction OPEN. • Set selector switch to position Local control (LOCAL) and reset fault indication via push button RESET.
Torque fault OPEN	Torque fault in direction OPEN	Perform one of the following measures: <ul style="list-style-type: none"> • Issue operation command in direction CLOSE. • Set selector switch to position Local control (LOCAL) and reset fault indication via push button RESET.
Phase fault	<ul style="list-style-type: none"> • When connecting to a 3-ph AC system and with internal 24 V DC supply of the electronics: Phase 2 is missing. • When connecting to a 3-ph or 1-ph AC system and with external 24 V DC supply of the electronics: One of the phases L1, L2 or L3 is missing. 	Test/connect phases.
Incorrect phase seq	The phase conductors L1, L2 and L3 are connected in the wrong sequence. Only applicable if connected to a 3-ph AC system.	Correct the sequence of the phase conductors L1, L2 and L3 by exchanging two phases.
Mains quality	Due to insufficient mains quality, the controls cannot detect the phase sequence (sequence of phase conductors L1, L2 and L3) within the pre-set time frame provided for monitoring.	<ul style="list-style-type: none"> • Check mains voltage. For 3-phase/1-phase AC current, the permissible variation of the mains voltage is $\pm 10\%$ (option $\pm 30\%$). The permissible variation of the mains voltage is $\pm 5\%$ • Check parameter Tripping time M0172, extend time frame if required.
Thermal fault	Motor protection tripped	<ul style="list-style-type: none"> • Cool down, wait. • If the fault indication display persists after cooling down: <ul style="list-style-type: none"> - Set selector switch to position Local control (LOCAL) and reset fault indication via push button RESET. • Check fuses.

Corrective action

Faults and Failure		
Indication on display	Description/cause	Remedy
Fault no reaction	No actuator reaction to operation commands within the set reaction time.	Check movement at actuator.
Poti Out of Range	Potentiometer is outside the permissible range.	Check device configuration: Parameter Low limit Uspan M0832 must be less than parameter Volt.level diff. potent. M0833 .
LPV not ready	LPV: Lift Plug Valve function The master actuator signals a fault	
Wrn input AIN 1	Loss of signal analogue input 1	Check wiring.
Wrn input AIN 2	Loss of signal analogue input 2	Check wiring.
Incorrect rotary direct.	Contrary to the configured direction of rotation and the active operation command, the motor turns into the wrong direction.	Check operation command control. For 3-phase AC current mains, activate phase monitoring (parameter Adapt rotary dir. M0171). Check device configuration setting (parameter Closing rotation M0176). To delete the fault indication: Disconnect actuator controls from the mains and perform reboot.
Syn. link deviation	Synchronous link function: Actual position values of master actuator and slave actuator are not synchronous (excessive deviation).	Check Deviation MA/SA [%] parameter.
Syn. link NotReady	Synchronous link function: Slave actuator is not ready.	Check Deviation MA/SA [%] parameter.
Syn. link wire break SA	Synchronous link function: Signal loss of actual position value from master actuator or slave actuator.	Check wiring.
DMF fault OPEN ¹⁾	The torque in direction OPEN, measured at the output drive shaft using the torque measurement flange, is too high.	Check DMF trip torque OP parameter. Check DMF fault level parameter.
DMF fault CLOSE ¹⁾	The torque in direction CLOSE, measured at the output drive shaft using the torque measurement flange, is too high.	Check DMF trip torque CL parameter. Check DMF fault level parameter.
FQM collective fault ²⁾	Collective signal 25:	Press push button  Details to display a list of individual indications. For a description of the individual signals, refer to Manual (Operation and setting).

- 1) For actuators equipped with torque measurement flange (DMF)
2) For actuators equipped with fail safe-unit

Table 24:

Not ready REMOTE and Function check (collective signal 04)		
Indication on display	Description/cause	Remedy
Wrong oper. cmd	Collective signal 13: Possible causes: <ul style="list-style-type: none"> Several operation commands (e.g. OPEN and CLOSE simultaneously, or OPEN and SET-POINT operation simultaneously) A setpoint is present and the positioner is not active 	<ul style="list-style-type: none"> Check operation commands (reset/clear all operation commands and send one operation command only). Set parameter Positioner to Function active. Check setpoint. Press push button  Details to display a list of individual indications. For a description of the individual signals, refer to Manual (Operation and setting).
Sel. sw. not REMOTE	Selector switch is not in position REMOTE.	Set selector switch to position REMOTE.
Service active	Operation via service interface (Bluetooth) and AUMA CDT service software.	Exit service software.
Disabled	Actuator is in operation mode Disabled.	Check setting and status of function <Local controls enable>.
EMCY stop active	The EMERGENCY stop switch has been operated. The motor control power supply (contactors or thyristors) is disconnected.	<ul style="list-style-type: none"> Enable EMERGENCY stop switch. Reset EMERGENCY stop state by means of Reset command.

Not ready REMOTE and Function check (collective signal 04)		
Indication on display	Description/cause	Remedy
EMCY behav. active	Operation mode EMERGENCY is active (EMERGENCY signal was sent). 0 V are applied at the EMERGENCY input.	<ul style="list-style-type: none"> • Detect cause for EMERGENCY signal. • Verify failure source. • Apply +24 V DC at EMERGENCY input.
I/O interface	The actuator is controlled via the I/O interface (parallel).	Check I/O interface.
Handwheel active	Manual operation is activated.	Start motor operation.
Interlock	An interlock is active.	Check interlock signal.
Interlock by-pass	By-pass function is interlocked.	Check states of main and by-pass valve.
PVST active	Partial Valve Stroke Test (PVST) is active.	Wait until PVST function is complete.
SIL function active ¹⁾	SIL function is active	

1) For actuators controls in SIL version

11.3. Fuses

11.3.1. Fuses within the actuator controls

Fuses used

F1/F2

Table 25:

Primary fuses F1/F2 (for power supply unit)

G fuse	F1/F2	AUMA art. no.
Size	6.3 x 32 mm	
Reversing contactors Power supply ≤ 500 V	1 A T; 500 V	K002.277
Reversing contactors Power supply > 500 V	2 A FF; 690 V	K002.665
Thyristor units for motor power up to 1.5 kW	1 A T; 500 V	K002.277
Thyristor units for motor power up to 3.0 kW		
Thyristor units for motor power up to 5.5 kW		

F3 Internal 24 V DC supply

Table 26:

Secondary fuses F3 (internal 24 V DC supply)

G fuse according to IEC 60127-2/III	F3	AUMA art. no.
Size	5 x 20 mm	
Voltage output (power supply unit) = 24 V	2.0 A T; 250 V	K006.106
Voltage output (power supply unit) = 115 V	2.0 A T; 250 V	K006.106

F4

Table 27:

Secondary fuses F4 (internal AC supply)¹⁾

G-fuse according to IEC 60127-2/III	F4	AUMA art. no.
Size	5 x 20 mm	
Voltage output (power supply unit) = 24 V	1.25 A T; 250 V	K001.184
Voltage output (power supply unit) = 115 V	—	—

1) Fuse for: Switch compartment heater, reversing contactor control, PTC tripping device (at 24 V AC only), at 115 V AC also control inputs OPEN, STOP, CLOSE

F5 Automatic reset fuse as short-circuit protection for external 24 V DC supply for customer (see wiring diagram)

Replace fuses F1/F2



Hazardous voltage!

Risk of electric shock.

→ Disconnect device from the mains before opening.

1. Loosen screws [1] and remove plug/socket connector [2].
Figure 71:

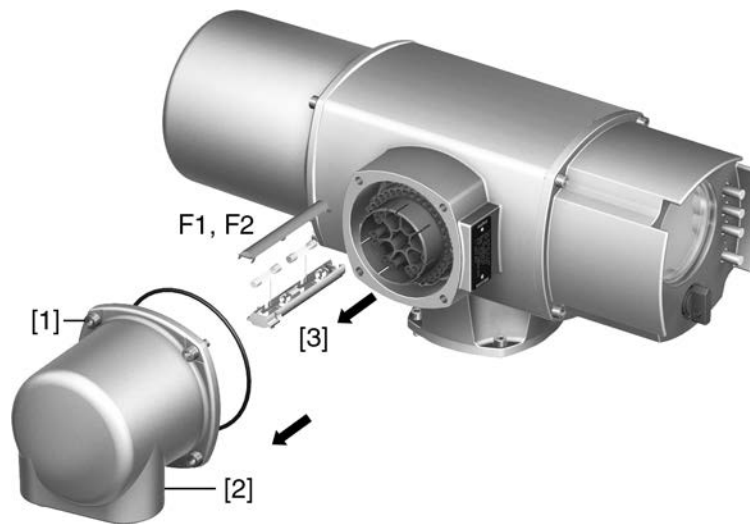

2. Pull fuse holder [3] out of pin carrier, open fuse cover and replace old fuses by new ones.

Test/replace fuses F3/F4

1. Loosen screws [1] and remove cover [2] on the rear of the actuator controls.
Figure 72:

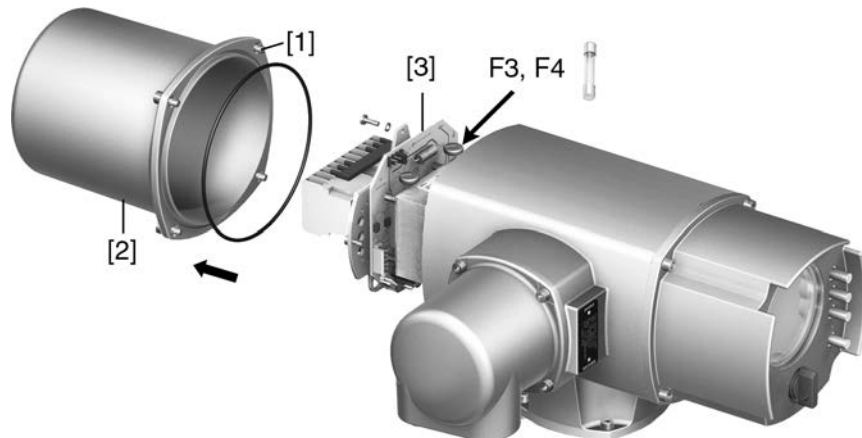

The power supply unit has measurement points (solder pins) allowing to perform a resistance (continuity) measurement:

Table 28:

Verifying	Measuring points
F3	MTP5 – MTP6
F4	MTP7 – MTP8

2. To replace defective fuses: Carefully loosen power supply unit [3] and pull out. (The fuses are on the equipped part of the power supply board).

NOTICE

Cable damage due to pinching!

Risk of functional failures.

→ Carefully assemble power supply unit to avoid pinching the cables.

11.3.2. Motor protection (thermal monitoring)

In order to protect against overheating and impermissibly high surface temperatures at the actuator, PTC thermistors or thermostiches are embedded in the motor winding. The thermostich is tripped as soon as the max. permissible winding temperature has been reached.

The actuator is switched off and the following signals are given:

- LED 3 (motor protection tripped) on the local controls is illuminated.
- Status indication **S0007** displays a fault.
The fault **Thermal fault** is displayed when selecting **Details**.

The motor has to cool down before operation can be resumed.

Depending on the parameter setting (motor protection behaviour), the fault signal is either automatically reset or the the fault signal has to be reset using **RESET** push button with selector switch position **Local operation** (LOCAL).

For further information to this topic, please refer to Manual (Operation and setting).

12. Servicing and maintenance



Damage caused by inappropriate maintenance!

- Servicing and maintenance must be carried out exclusively by suitably qualified personnel having been authorised by the end user or the contractor of the plant. Therefore, we recommend contacting our service.
- Only perform servicing and maintenance tasks when the device is switched off.

AUMA Service & Support

AUMA offers extensive service such as servicing and maintenance as well as customer product training. For the relevant contact addresses, please refer to <Addresses> in this document or to the Internet (www.auma.com)

12.1. Preventive measures for servicing and safe operation

The following actions are required to ensure safe device operation:

6 months after commissioning and then once a year

- Carry out visual inspection:
Check threaded plugs, cable entries, cable glands, blanking plugs, etc. for correct tightness and sealing.
Consider torques according to manufacturer's details.
- Check fastening screws between actuator and gearbox/valve for tightness. If required, fasten screws while applying the tightening torques as indicated in chapter <Assembly>.
- When rarely operated: Perform test run.
- For devices with output drive type A: Press in Lithium soap EP multi-purpose grease on mineral oil base at the grease nipple with a grease gun.
- Lubrication of the valve stem must be done separately.

Figure 73: Output drive type A

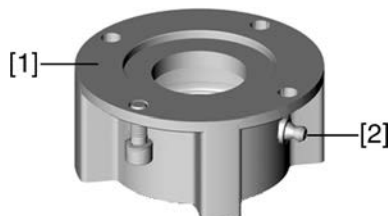

- [1] Output drive type A
- [2] Grease nipple

Table 29:

Grease quantities for bearing of output drive type A				
Output drive type	A 07.2	A 10.2	A 14.2	A 16.2
Quantity [g] ¹⁾	1.5	3	5	10

1) For grease with density $\rho = 0.9 \text{ kg/dm}^3$

For enclosure protection IP68

After submersion:

- Check actuator.
- In case of ingress of water, locate leaks and repair. Dry device correctly and check for proper function.

12.2. Maintenance

- Lubrication** • In the factory, the gear housing is filled with grease.

- Grease change is performed during maintenance
 - Generally after 4 to 6 years for modulating duty.
 - Generally after 6 to 8 years if operated frequently (open-close duty).
 - Generally after 10 to 12 years if operated infrequently (open-close duty).
- We recommend replacing the seals when changing the grease.
- Additional lubrication of the gear housing is not required during operation.

12.3. Disposal and recycling

Our devices have a long lifetime. However, they have to be replaced at one point in time. The devices have a modular design and may, therefore, easily be separated and sorted according to materials used, i.e.:

- various metals
- plastics
- greases and oils

The following generally applies:

- Greases and oils are hazardous to water and must not be released into the environment.
- Arrange for controlled waste disposal of the disassembled material or for separate recycling according to materials.
- Observe the national regulations for waste disposal.

13. Technical data

Information The following tables include standard and optional features. For detailed information on the customer-specific version, refer to the order-related data sheet. The technical data sheet can be downloaded from the Internet in both German and English at <http://www.auma.com> (please state the order number).

13.1. Technical data Multi-turn actuators

Features and functions	
Type of duty (Multi-turn actuators for open-close duty)	Standard: Short-time duty S2 - 15 min, classes A and B according to EN 15714-2
	Option: with 3-phase AC motor: Short-time duty S2 - 30 min, classes A and B according to EN 15714-2 For nominal voltage and 40 °C ambient temperature and at load with 35 % of the max. torque.
Type of duty (Multi-turn actuators for modulating duty)	Standard: Intermittent duty S4 - 25 %, class C according to EN 15714-2
	Option: with 3-phase AC motor: Intermittent duty S4 - 50 %, class C according to EN 15714-2 Intermittent duty S4 - 25 % (insulation class H required), class C according to EN 15714-2 For nominal voltage and 40 °C ambient temperature and at modulating torque load.
Motors	Standard: 3-phase AC asynchronous motor, type IM B9 according to IEC 60034-7, IC410 cooling procedure according to IEC 60034-6
	Option: 1-phase AC motor with permanent split capacitor (PSC), type IM B9 according to IEC 60034-7, IC410 cooling procedure according to IEC 60034-6
	1-phase AC motor with integral starting capacitor and solid state switch (CSIR), type IM B9 according to IEC 60034-7, IC410 cooling procedure according to IEC 60034-6
	DC shunt motor, type IM B14 according to IEC 60034-7, cooling procedure IC410 according to IEC 60034-6 DC compound motor, type IM B14 according to IEC 60034-7, cooling procedure IC410 according to IEC 60034-6
Mains voltage, mains frequency	Refer to name plate of actuator controls Permissible variation of mains voltage: ±10 % Permissible variation of mains frequency: ±5 % (for 3-phase and 1-phase AC current)
Overvoltage category	Category III according to IEC 60364-4-443
Insulation class	Standard: F, tropicalized
	Option: H, tropicalized (with 3-phase AC motor)
Motor protection	Standard: 3-phase and 1-phase AC motors: Thermoswitches (NC) DC motors: Without
	Option: PTC thermistors (according to DIN 44082) PTC thermistors additionally require a suitable tripping device in the actuator controls.
Self-locking	Self-locking: Output speeds up to 90 rpm (50 Hz), 108 rpm (60 Hz) NOT self-locking: Output speeds from 125 rpm (50 Hz), 150 rpm (60 Hz) Multi-turn actuators are self-locking, if the valve position cannot be changed from standstill while torque acts upon the output drive.
Motor heater (option)	Voltages: 110 – 120 V AC, 220 – 240 V AC (3-phase and 1-phase AC motors) 380 – 480 V AC (3-phase AC motors) DC motors: Without motor heater
	Power depending on the size 12.5 – 25 W
Manual operation	Manual drive for setting and emergency operation, handwheel does not rotate during electrical operation.
	Option: Handwheel lockable Handwheel stem extension Power tool for emergency operation with square 30 mm or 50 mm
Indication for manual operation (option)	Indication whether manual operation is active/not active via single switch (1 change-over contact)

Features and functions	
Electrical connection	Standard: AUMA plug/socket connector with screw-type connection Motor connection for some DC motors via separate motor terminal board
	Option: Terminals or crimp connection Gold-plated control plug (sockets and pins)
Threads for cable entries	Standard: Metric threads
	Option: Pg-threads, NPT-threads, G-threads
Terminal plan	Terminal plan according to order number enclosed with delivery
Valve attachment	Standard: B1 according to EN ISO 5210
	Option: A, B2, B3, B4 according to EN ISO 5210 A, B, D, E according to DIN 3210 C according to DIN 3338
	Special valve attachments: AF, AK, AG, B3D, ED, DD, IB1, IB3 A prepared for permanent lubrication of stem

Electronic control unit (option, only in combination with AC actuator controls)	
Non-Intrusive setting	Magnetic limit and torque transmitter (MWG) Turns per stroke: 1 to 500 (standard) or 10 to 5,000 (option)
Position feedback signal	Via actuator controls
Torque feedback signal	Via actuator controls
Mechanical position indicator (option)	Continuous indication, adjustable indicator disc with symbols OPEN and CLOSED
Running indication	Blinking signal via actuator controls
Heater in switch compartment	Resistance type heater with 5 W, 24 V AC

Service conditions	
Use	Indoor and outdoor use permissible
Mounting position	Any position
Installation altitude	≤ 2 000 m above sea level > 2,000 m above sea level, on request
Ambient temperature	Standard: –30 °C to +70 °C
	Options: –40 °C to +70 °C –40 °C to +80 °C (multi-turn actuators for open-close duty with 3-phase/1-phase AC motors) –60 °C to +60 °C (with 3-phase/1-phase AC motors) 0 °C to +120 °C (multi-turn actuators for open-close duty with 3-phase AC motor) 0 °C to +100 °C (multi-turn actuators for modulating duty with 3-phase AC motor)
	For exact version, refer to actuator name plate.
Humidity	Up to 100 % relative humidity across the entire permissible temperature range
Enclosure protection according to EN 60529	Standard: IP68 (with AUMA 3-phase/1-phase AC or DC motor) For special motors differing enclosure protection available (refer to motor name plate)
	Option: DS Terminal compartment additionally sealed against interior (double sealed)
	According to AUMA definition, enclosure protection IP68 meets the following requirements: <ul style="list-style-type: none"> • Depth of water: Maximum 8 m head of water • Duration of continuous immersion in water: Maximum 96 hours • Up to 10 operations during flooding. • Modulating duty is not possible during continuous immersion. For exact version, refer to actuator name plate.
Pollution degree according to IEC 60664-1	Pollution degree 4 (when closed), pollution degree 2 (internal)
Vibration resistance according to IEC 60068-2-6	2 g, from 10 to 200 Hz (for actuators in AUMA NORM version) 1 g, from 10 to 200 Hz (for actuators with mounted AUMA actuator controls)
	Resistant to vibration during start-up or for failures of the plant. However, a fatigue strength may not be derived from this. Indications apply to actuators with AUMA 3-phase AC motor and AUMA plug/socket connector. They are not valid in combination with gearboxes.

Service conditions	
Corrosion protection	Standard: KS: Suitable for use in areas with high salinity, almost permanent condensation, and high pollution.
	Option: KX: Suitable for use in areas with extremely high salinity, permanent condensation, and high pollution.
	KX-G : same as KX, however aluminium-free version (outer parts)
Coating	Double layer powder coating Two-component iron-mica combination
Colour	Standard: AUMA silver-grey (similar to RAL 7037)
	Option: Other colours are possible on request.
Lifetime	AUMA multi-turn actuators meet or exceed the lifetime requirements of EN 15714-2. For further details, please contact AUMA
Noise level	< 72 dB (A)

Further information	
EU Directives	Electromagnetic Compatibility (EMC): (2014/30/EU) Low Voltage Directive: (2014/35/EU) Machinery Directive: (2006/42/EC)

Technical data for handwheel activation switches	
Mechanical lifetime	10 ⁶ starts
Silver plated contacts:	
U min.	12 V DC
U max.	250 V AC
I max. AC current	3 A at 250 V (inductive load, cos phi = 0.8)
I max. DC current	3 A at 12 V (resistive load)

13.2. Technical data Actuator controls

Features and functions	
Power supply	Refer to name plate Permissible variation of mains voltage: ±10 % Permissible variation of mains voltage: ±30 % (optional) Permissible variation of mains frequency: ±5 %
External supply of the electronics (option)	24 V DC +20 %/-15 % Current consumption: Basic version approx. 250 mA, with options up to 500 mA External power supply must have reinforced insulation against mains voltage in accordance with IEC 61010-1 and may only be supplied by a circuit limited to 150 VA in accordance with IEC 61010-1.
Current consumption	Current consumption of the actuator controls depending on mains voltage: For permissible variation of mains voltage of ±10 %: <ul style="list-style-type: none"> • 100 to 120 V AC = max. 740 mA • 208 to 240 V AC = max. 400 mA • 380 to 500 V AC = max. 250 mA • 515 to 690 V AC = max. 200 mA For permissible variation of mains voltage of ±30 %: <ul style="list-style-type: none"> • 100 to 120 V AC = max. 1,200 mA • 208 to 240 V AC = max. 750 mA • 380 to 500 V AC = max. 400 mA • 515 to 690 V AC = max. 400 mA
Overvoltage category	Category III according to IEC 60364-4-443
Rated power	The actuator controls are designed for the nominal motor power, refer to motor name plate

Features and functions	
Switchgear	Standard: Reversing contactors (mechanically and electrically interlocked) for AUMA power classes A1/A2
	Options: Reversing contactors (mechanically and electrically interlocked) for AUMA power class A3 Thyristor unit for mains voltage up to 500 V AC (recommended for modulating actuators) for AUMA power classes B1, B2 and B3
	The reversing contactors are designed for a lifetime of 2 million starts. For applications requiring a high number of starts, we recommend the use of thyristor units. For the assignment of AUMA power classes, please refer to Electrical data on actuator
Control inputs	6 digital inputs: OPEN, STOP, CLOSE, EMERGENCY (via opto-isolator, thereof OPEN, STOP, CLOSE with one common and EMERGENCY without common, respect minimum pulse duration for modulating actuators).
Control voltage/current consumption for control inputs	Standard 24 V DC, current consumption: approx. 10 mA per input
	Options: 48 V DC, current consumption: approx. 7 mA per input 60 V DC, current consumption: approx. 9 mA per input 115 V DC, current consumption: approx. 15 mA per input 100 – 120 V AC, current consumption : approx. 15 mA per input
All input signals must be supplied with the same potential.	
Status signals (output signals)	Standard: <ul style="list-style-type: none"> • 6 programmable output contacts: <ul style="list-style-type: none"> - 5 potential-free NO contacts with one common, max. 250 V AC, 1 A (resistive load) Default configuration: End position CLOSED, end position OPEN, selector switch REMOTE, torque fault CLOSE, torque fault OPEN - 1 potential-free change-over contact, max. 250 V AC, 5 A (resistive load) Default configuration: Collective fault signal (torque fault, phase failure, motor protection tripped) • Analogue output signal for position feedback <ul style="list-style-type: none"> - Galvanically isolated position feedback 0/4 – 20 mA (load max. 500 Ω)
	Options: <ul style="list-style-type: none"> • 6 programmable output contacts: <ul style="list-style-type: none"> - 5 change-over contacts with one common, max. 250 V AC, 1 A (resistive load), 1 potential-free change-over contact, max. 250 V AC, 5 A (resistive load) • 12 programmable output contacts: <ul style="list-style-type: none"> - 10 potential-free NO contacts, 5 with one common each, max. 250 V AC, 1 A (resistive load), 2 potential-free change-over contacts, max. 250 V AC, 5 A (resistive load) • 6 programmable output contacts: <ul style="list-style-type: none"> - 6 potential-free change-over contacts without one common, per contact max. 250 V AC, 5 A (resistive load) • 10 programmable output contacts: <ul style="list-style-type: none"> - 10 potential-free change-over contacts without one common, per contact max. 250 V AC, 5 A (resistive load) • 6 programmable output contacts: <ul style="list-style-type: none"> - 4 mains failure proof potential-free NO contacts with one common, max. 250 V AC, 1 A (resistive load), 1 potential-free NO contact, max. 250 V AC, 1 A (resistive load), 1 potential-free change-over contact, max. 250 V AC, 5 A (resistive load) • 6 programmable output contacts: <ul style="list-style-type: none"> - 4 mains failure proof potential-free NO contacts, max. 250 V AC, 5 A (resistive load), 2 potential-free change-over contacts, max. 250 V AC, 5 A (resistive load), • 12 programmable output contacts: <ul style="list-style-type: none"> - 8 mains failure proof potential-free NO contacts, max. 250 V AC, 1 A (resistive load), 2 potential-free NO contacts, max. 250 V AC, 1 A (resistive load), 2 potential-free change-over contacts, max. 250 V AC, 5 A (resistive load) • 12 programmable output contacts: <ul style="list-style-type: none"> - 8 mains failure proof potential-free NO contacts, max. 250 V AC, 5 A (resistive load), 4 potential-free change-over contacts, max. 250 V AC, 5 A (resistive load), All output signals must be supplied with the same potential.
Voltage output	Standard: Auxiliary voltage 24 V DC: max. 100 mA for supply of control inputs, galvanically isolated from internal voltage supply.
	Option: Auxiliary voltage 115 V AC: max. 30 mA for supply of control inputs, galvanically isolated from internal voltage supply (Not possible in combination with PTC tripping device)

Features and functions	
Analogue output (option)	2 analogue outputs: With position transmitter option: Output of travel and torque as continuous values between 0/4 and 20 mA
Analogue input (option)	2 analogue inputs: With positioner/process controller option: Input of actual position value/actual process value as continuous values between 0/4 and 20 mA
Local controls	Standard: <ul style="list-style-type: none"> • Selector switch: LOCAL - OFF - REMOTE (lockable in all three positions) • Push buttons OPEN, STOP, CLOSE, RESET <ul style="list-style-type: none"> - Local STOP The actuator can be stopped via push button STOP of local controls if the selector switch is in position REMOTE. (Not activated when leaving the factory.) • 6 indication lights: <ul style="list-style-type: none"> - End position and running indication CLOSED (yellow), torque fault CLOSE (red), motor protection tripped (red), torque fault OPEN (red), end position and running indication OPEN (green), Bluetooth (blue) • Graphic LC display: illuminated
	Option: <ul style="list-style-type: none"> • Special colours for the indication lights: <ul style="list-style-type: none"> - End position CLOSED (green), torque fault CLOSE (blue), torque fault OPEN (yellow), motor protection tripped (violet), end position OPEN (red)
Bluetooth Communication interface	Bluetooth class II chip, version 2.1: With a range up to 10 m in industrial environments, supports the SPP Bluetooth profile (Serial Port Profile). Required accessories: <ul style="list-style-type: none"> • AUMA CDT (Commissioning and Diagnostic Tool for Windows-based PC) • AUMA Assistant App (Commissioning and Diagnostic Tool for Android devices)
Application functions	Standard: <ul style="list-style-type: none"> • Selectable type of seating, limit or torque seating for end position OPEN and end position CLOSED • Torque by-pass: Adjustable duration (with adjustable peak torque during start-up time) • Start and end of stepping mode as well as ON and OFF times can be set individually for directions OPEN and CLOSE, 1 to 1,800 seconds • Any 8 intermediate positions: can be set between 0 and 100 %, reaction and signal behaviour programmable • Running indication blinking: can be set
	Options: <ul style="list-style-type: none"> • Positioner <ul style="list-style-type: none"> - Position setpoint via analogue input 0/4 – 20 mA - Programmable behaviour on loss of signal - Automatic adaptation of dead band (adaptive behaviour selectable) - Split range operation - MODE input for selecting between OPEN-CLOSE and setpoint control • PID process controller: with adaptive positioner, via 0/4 – 20 mA analogue inputs for process setpoint and actual process value • Multiport valve: Up to 16 positions, signals (pulse or edge) • Automatic deblocking: Up to 5 operation trials, travel time in opposite direction can be set • Static and dynamic torque recording for both rotation directions with torque measurement flange as additional accessory
Safety functions	Standard: <ul style="list-style-type: none"> • EMERGENCY operation (programmable behaviour) <ul style="list-style-type: none"> - Digital input: Low active - Reaction can be selected: Stop, run to end position CLOSED, run to end position OPEN, run to intermediate position - Torque monitoring can be by-passed during EMERGENCY operation - Thermal protection can be by-passed during EMERGENCY operation (only in combination with thermoswitch within actuator, not with PTC thermistor).
	Options: <ul style="list-style-type: none"> • Enabling local controls via digital input Enable LOCAL. Thus, actuator operation can be enabled or disabled via push buttons on the local controls. • Interlock for main/by-pass valve: Enabling the operation commands OPEN or CLOSE via two digital inputs • EMERGENCY Stop push button (latching): interrupts electrical operation, irrespective of the selector switch positions. • PVST (Partial Valve Stroke Test): programmable to check the function of both actuator and actuator controls: Direction, stroke, operation time, reversing time

Features and functions	
Monitoring functions	<ul style="list-style-type: none"> Valve overload protection: adjustable, results in switching off and generates fault signal Motor temperature monitoring (thermal monitoring): results in switching off and generates fault indication Monitoring the heater within actuator: generates warning signal Monitoring of permissible on-time and number of starts: adjustable, generates warning signal Operation time monitoring: adjustable, generates warning signal Phase failure monitoring: results in switching off and generates fault signal Automatic correction of rotation direction upon wrong phase sequence (3-ph AC current)
Diagnostic functions	<ul style="list-style-type: none"> Electronic device ID with order and product data Logging of operating data: A resettable counter and a lifetime counter each for: <ul style="list-style-type: none"> Motor running time, number of starts, torque switch trippings in end position CLOSED, limit switch trippings in end position CLOSED, torque switch trippings in end position OPEN, limit switch trippings in end position OPEN, torque faults CLOSE, torque faults OPEN, motor protection trippings Time-stamped event report with history for setting, operation and faults Status signals according to NAMUR recommendation NE 107: "Failure", "Function check", "Out of specification", "Maintenance required" Torque characteristics (for version with MWG in actuator): <ul style="list-style-type: none"> 3 torque characteristics (torque-travel characteristic) for opening and closing directions can be saved separately. Torque characteristics stored can be shown on the display.
Motor protection evaluation	Standard: Monitoring the motor temperature in combination with thermostiches within actuator motor
	Options: <ul style="list-style-type: none"> Thermal overload relay in controls combined with thermostiches within actuator PTC tripping device in combination with PTC thermistors within actuator motor
Electrical connection	Standard: AUMA plug/socket connector with screw-type connection
	Option: Gold-plated control plug (sockets and plugs)
Threads for cable entries	Standard: Metric threads
	Options: Pg-threads, NPT-threads, G-threads
Wiring diagram	Refer to name plate

Further options for Non-intrusive version with MWG in the actuator	
Setting of limit and torque switching via local controls	
Torque feedback signal	Galvanically isolated analogue output 0/4 – 20 mA (load max. 500 Ω).

Service conditions	
Use	Indoor and outdoor use permissible
Mounting position	Any position
Installation altitude	≤ 2,000 m above sea level > 2,000 m above sea level, on request
Ambient temperature	Refer to name plate of actuator controls
Humidity	Up to 100 % relative humidity across the entire permissible temperature range
Enclosure protection according to EN 60529	Standard: IP68
	Option: Terminal compartment additionally sealed against interior of actuator controls (double sealed)
	According to AUMA definition, enclosure protection IP68 meets the following requirements: <ul style="list-style-type: none"> Depth of water: Maximum 8 m head of water Duration of continuous immersion in water: Maximum 96 hours Up to 10 operations during continuous immersion Modulating duty is not possible during continuous immersion. For exact version, refer to actuator controls name plate.
Pollution degree according to IEC 60664-1	Pollution degree 4 (when closed), pollution degree 2 (internal)

Service conditions		
Corrosion protection	Standard:	KS: Suitable for use in areas with high salinity, almost permanent condensation, and high pollution.
	Option:	KX: Suitable for use in areas with extremely high salinity, permanent condensation, and high pollution.
Coating	Double layer powder coating Two-component iron-mica combination	
Colour	Standard:	AUMA silver-grey (similar to RAL 7037)
	Option:	Available colours on request

Accessories	
Wall bracket	For actuator controls mounted separately from the actuator, including plug/socket connector. Connecting cable on request. Recommended for high ambient temperatures, difficult access, or heavy vibration during service. Cable length between actuator and actuator controls is max. 100 m (Not suitable for version with potentiometer in the actuator). Instead of the potentiometer, the actuator has to be equipped with an electronic position transmitter. (MWG requires a separate data cable.)
Programming software	AUMA CDT (Commissioning and Diagnostic Tool for Windows-based PC) AUMA Assistant App (Commissioning and Diagnostic Tool for Android devices)
Torque measurement flange DMF	Accessory for torque measurement for SA/SAR 07.2 – SA/SAR 16.2

Further information	
Weight	Approx. 7 kg (with AUMA plug/socket connector)
EU Directives	Electromagnetic Compatibility (EMC): (2014/30/EU) Low Voltage Directive: (2014/35/EU) Machinery Directive: (2006/42/EC)

14. Spare parts

14.1. Multi-turn actuators SA 07.2 – SA 16.2/SAR 07.2 – SAR 16.2

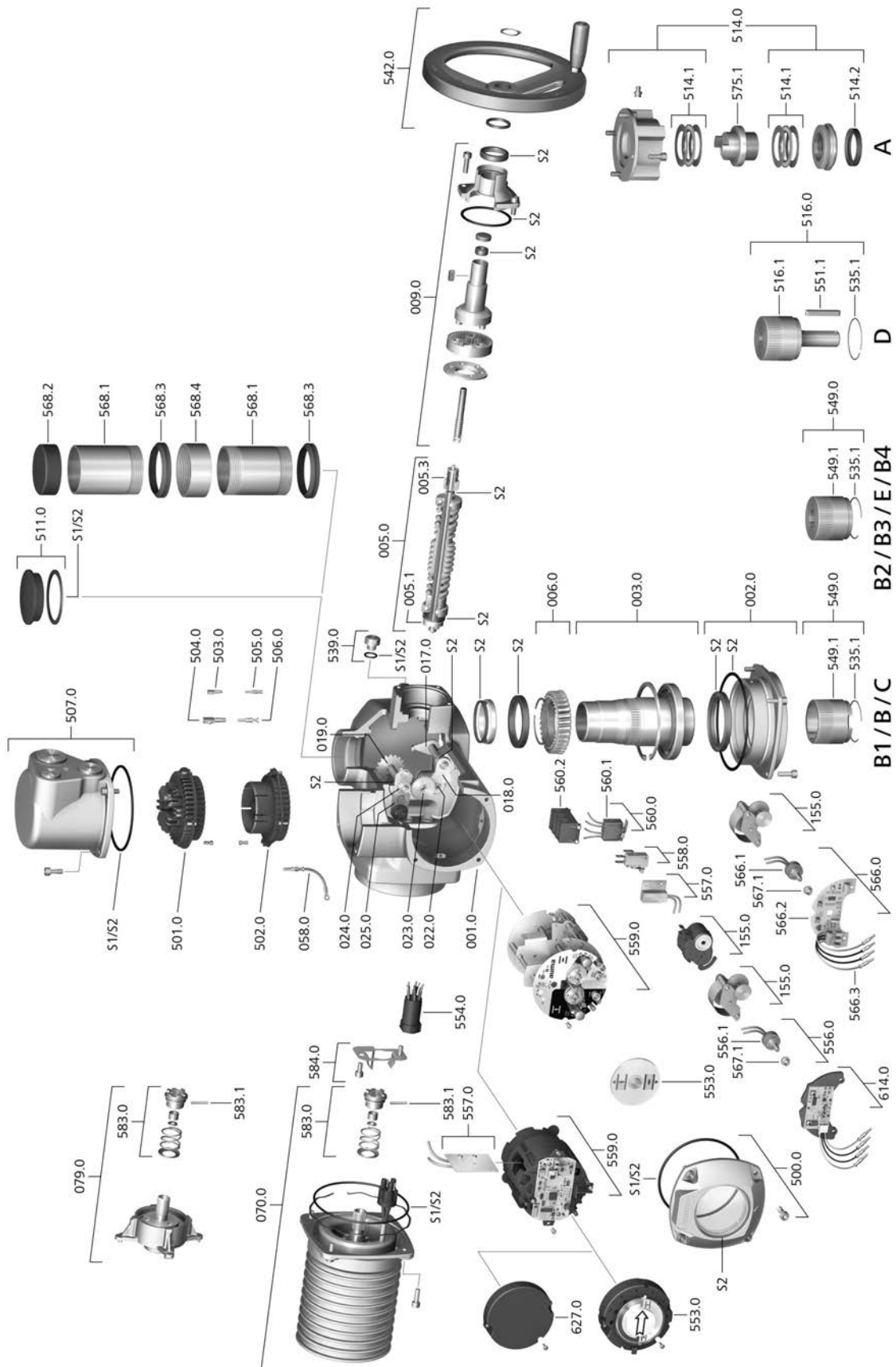

Please state device type and our order number (see name plate) when ordering spare parts. Only original AUMA spare parts should be used. Failure to use original spare parts voids the warranty and exempts AUMA from any liability. Representation of spare parts may slightly vary from actual delivery.

Ref. no.	Designation	Type	Ref. no.	Designation	Type
001.0	Housing	Sub-assembly	539.0	Screw plug	Sub-assembly
002.0	Bearing flange	Sub-assembly	542.0	Handwheel with ball handle	Sub-assembly
003.0	Hollow shaft	Sub-assembly	549.0	Output drive types B/B1/B2/B3/B4/C/E	Sub-assembly
005.0	Drive shaft	Sub-assembly	549.1	Output drive sleeve B/B1/B2/B3/B4/C/E	Sub-assembly
005.1	Motor coupling		551.1	Parallel key	
005.3	Manual drive coupling		553.0	Mechanical position indicator	Sub-assembly
006.0	Worm wheel		554.0	Socket carrier for motor plug/socket connector with cable harness	Sub-assembly
009.0	Manual gearing	Sub-assembly	556.0	Potentiometer as position transmitter	Sub-assembly
017.0	Torque lever	Sub-assembly	556.1	Potentiometer without slip clutch	Sub-assembly
018.0	Gear segment		557.0	Heater	
019.0	Crown wheel		558.0	Blinker transmitter including pins at wires (without impulse disc and insulation plate)	Sub-assembly
022.0	Drive pinion II for torque switching	Sub-assembly	559.0-1	Electromechanical control unit with switches, including torque switching heads	Sub-assembly
023.0	Output drive wheel for limit switching	Sub-assembly	559.0-2	Electronic control unit with magnetic limit and torque transmitter (MWG)	Sub-assembly
024.0	Drive wheel for limit switching	Sub-assembly	560.0-1	Switch stack for direction OPEN	Sub-assembly
025.0	Locking plate	Sub-assembly	560.0-2	Switch stack for direction CLOSE	Sub-assembly
058.0	Cable for protective earth	Sub-assembly	560.1	Switch for limit/torque	Sub-assembly
070.0	Motor (only for V... motors incl. ref. no. 079.0)	Sub-assembly	560.2	Switch case	
079.0	Planetary gearing for motor drive (only for V... motors)	Sub-assembly	566.0	RWG position transmitter	Sub-assembly
155.0	Reduction gearing	Sub-assembly	566.1	Potentiometer for RWG without slip clutch	Sub-assembly
500.0	Cover	Sub-assembly	566.2	Position transmitter board for RWG	Sub-assembly
501.0	Socket carrier (complete with sockets)	Sub-assembly	566.3	Cable set for RWG	Sub-assembly
502.0	Pin carrier without pins	Sub-assembly	567.1	Slip clutch for potentiometer	Sub-assembly
503.0	Socket for controls	Sub-assembly	568.1	Stem protection tube (without cap)	
504.0	Socket for motor	Sub-assembly	568.2	Protective cap for stem protection tube	
505.0	Pin for controls	Sub-assembly	568.3	V-seal	
506.0	Pin for motor	Sub-assembly	568.4	Threaded sleeve	
507.0	Cover for electrical connection	Sub-assembly	575.1	Stem nut A (without thread)	
511.0	Threaded plug	Sub-assembly	583.0	Motor coupling on motor shaft	Sub-assembly
514.0	Output drive type A (without stem nut)	Sub-assembly	583.1	Pin for motor coupling	
514.1	Axial needle roller bearing	Sub-assembly	584.0	Retaining spring for motor coupling	Sub-assembly
514.2	Radial seal for output drive type A		614.0	EWG position transmitter	Sub-assembly
516.0	Output drive type D	Sub-assembly	627.0	MWG 05.03 cover	
516.1	Output drive shaft D		S1	Seal kit, small	Set
535.1	Snap ring		S2	Seal kit, large	Set

14.2. AC 01.2 actuator controls

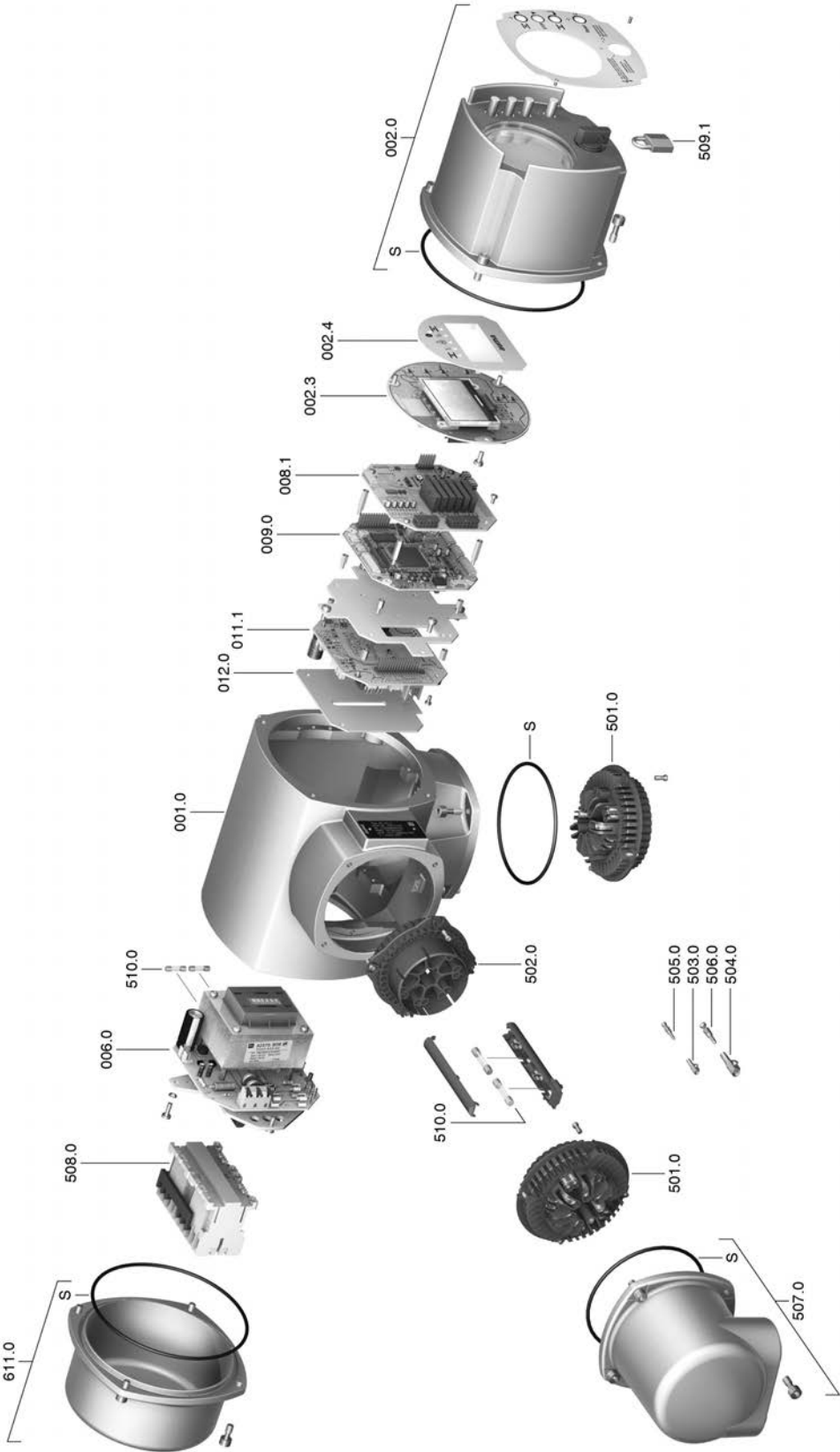

Spare parts

Please state device type and our order number (see name plate) when ordering spare parts. Only original AUMA spare parts should be used. Failure to use original spare parts voids the warranty and exempts AUMA from any liability. Representation of spare parts may slightly vary from actual delivery.

Ref. no.	Designation	Type
001.0	Housing	Sub-assembly
002.0	Local controls	Sub-assembly
002.3	Local controls board	Sub-assembly
002.4	Display face plate	
006.0	Power supply	Sub-assembly
008.1	I/O board	Sub-assembly
009.0	Logic board	Sub-assembly
011.1	Relay board	Sub-assembly
012.0	Option board	
501.0	Socket carrier complete with sockets	Sub-assembly
502.0	Pin carrier without pins	
503.0	Socket for controls	Sub-assembly
504.0	Socket for motor	Sub-assembly
505.0	Pin for controls	Sub-assembly
506.0	Pin for motor	Sub-assembly
507.0	Cover for electrical connection	Sub-assembly
508.0	Switchgear	Sub-assembly
509.1	Padlock	Sub-assembly
510.0	Fuse kit	Set
611.0	Cover	Sub-assembly
S	Seal kit	Set

15. Certificates

Information Certificates are valid as from the indicated date of issue. Subject to changes without notice. The latest versions are attached to the device upon delivery and also available for download at <http://www.auma.com>.

15.1. Declaration of Incorporation and EC Declaration of Conformity

AUMA Riester GmbH & Co. KG
Aumastr. 1
79379 Müllheim, Germany
www.auma.com

Tel +49 7631 809-0
Fax +49 7631 809-1250
info@auma.com



EU Declaration of Conformity / Declaration of Incorporation in compliance with Machinery Directive

for electric actuators of the following type designations:

**SA 07.2, SA 07.6, SA 10.2, SA 14.2, SA 14.6, SA 16.2,
SAR 07.2, SAR 07.6, SAR 10.2, SAR 14.2, SAR 14.6, SAR 16.2
SQ 05.2, SQ 07.2, SQ 10.2, SQ 12.2, SQ 14.2
SQR 05.2, SQR 07.2, SQR 10.2, SQR 12.2, SQR 14.2**

in versions:

**AUMA NORM
AUMA SEMIPACT SEM 01.1, SEM 02.1
AUMA MATIC AM 01.1, AM 02.1
AUMATIC AC 01.2**

AUMA Riester GmbH & Co. KG as manufacturer declare herewith, that the above mentioned actuators meet the basic requirements of the following Directives:

**2014/30/EU (EMC Directive)
2006/42/EC (Machinery Directive)**

The following harmonised standards in terms of the specified directives have been applied:

Directive 2014/30/EU

EN 61000-6-4:2007 / A1:2011
EN 61000-6-2:2005 / AC:2005

Directive 2006/42/EC

EN ISO 12100:2010
EN ISO 5210:1996

AUMA actuators are designed for the operation of industrial valves. Putting into service is prohibited until the final machinery has been declared in conformity with the provisions of Directive 2006/42/EC.

The following basic requirements in compliance with Annex I of the Directive are respected:

Appendix I, articles 1.1.2, 1.1.3, 1.1.5, 1.2.1, 1.2.6, 1.3.1, 1.3.7, 1.5.1, 1.6.3, 1.7.1, 1.7.3, 1.7.4

The manufacturer shall be obligated to electronically submit the documents for the partly completed machinery to national authorities on request. The relevant technical documentation pertaining to the machinery described in Annex VII, part B has been prepared.

Authorised person for documentation: Peter Malus, Aumastrasse 1, 79379 Müllheim, Germany

Furthermore, the essential health and safety requirements in compliance with Directive 2014/35/EU (Low Voltage Directive) are fulfilled by applying the following harmonised standards, as far as applicable for the products:

EN 60204-1:2006 / A1:2009 / AC:2010
EN 60034-1:2010 / AC:2010
EN 50178:1997

Müllheim, 2016-04-01

H. Newerla, Managing Director

This declaration does not contain any guarantees. The safety instructions in product documentation supplied with the devices must be observed. Non-concerted modification of the devices voids this declaration.

Y006.332/003/en/1.16

Index

A

Accessories (electrical connection)	29
Accessories for assembly	21
Actual value - indication on display	41
Actuator controls terminal plan	9
Actuator operation at the local controls	33
Actuator operation from remote	34
Actuator terminal plan	9, 10
Ambient temperature	8, 9, 73, 77
Analogue signals	47
Applications	5
Assembly	16

C

Cable entries	73
Cables	24
Cable set	29
Certificates	83
Coating	78
Colour	78
Commissioning	5
Commissioning (indications on display)	39
Commission number	8
Connecting cable	29
Connecting cables	24
Control	9, 11
Control inputs Potential	24
Control voltage	11
Corrective action	63
Corrosion protection	14, 74, 78
Current consumption	23
Current type	9, 23

D

Data Matrix code	11
Declaration of Incorporation	83
Device type	10
Digital outputs	47
Direct display via ID	36
Direction of rotation	54, 55
Directives	5
Display (indications)	39
Disposal	71
Double sealed	30

E

Earth connection	31
EC Declaration of Conformity	83
Electrical connection	23, 73
EMC	25
Enclosure protection	8, 9, 9, 73, 77
Error - indication on display	39

F

Failure - indication on display	44
Fault	63
Fault - indication on display	43
Features and functions	77
Flange size	10
Frequency range	23
Function check - indication on display	44
Fuses	67

H

Handwheel	16
Heating system	24
Hollow shaft	55
Humidity	73

I

Identification	8
Indication lights	45
Indications	39
Indications on display	39
Indicator disc	46, 58, 60
Indicator mark	46
Input current	11
Input signal	11
Input signals Potential	24
Inspection certificate	10
Installation altitude	77
Insulation class	9, 72
Intermediate frame	30
Intermediate position indication via LEDs	45
Intrusive	11

L

Language in the display	37
LEDs (indication lights)	45
Lifetime	74
Local actuator operation	33
Local control	33
Local controls	33
Local setting	34
Lubrication	70

M		P	
Main menu	35	Packaging	14
Mains frequency	9, 9, 72	Parking frame	30
Mains voltage	9, 9, 23, 72	Password	36
Maintenance	5, 70, 70	Password change	37
Maintenance required - indication on display	44	Password entry	36
Manual operation	32, 72	Positioner - indication on display	41
Mechanical position indicator	46, 46, 58, 60	Position indicator	46, 46, 58, 60
Mechanical position indicator (self-adjusting)	58	Positions – indication on display	42
Menu navigation	34	Position transmitter	10
Motor heater	72	Power class	9
Motor operation	33	Power class for switchgear	10
Motor protection	9, 72	Power factor	9
Motors	72	Power supply of electronics	23
Motor type	9	Production, year	10
Mounting position	77	Protection on site	23
Multiport valve positions – indication on display	42	Protective measures	5
		Push-to-run operation	33
N		Q	
Name plate	8	Qualification of staff	5
Nominal current	9		
Nominal power	9	R	
Non-Intrusive	11	Range of application	5
Not ready REMOTE - indication on display	43	Recycling	71
		Reduction gearing	60
O		Remote actuator operation	34
Operation	5, 32	Residual current device (RCD)	24
Operation commands - indications on display	41	Running indication	46, 46
Order number	8, 9, 10		
Out of specification - indication on display	43		
Output contacts	47		
Output drive type A	16		
Output drive types B	19		
Output signals	47		
Output signals Potential	24		
Output speed	8, 9		
Overvoltage category	72, 74		

S		Y	
Safety instructions	5	Year of production	10
Safety instructions/warnings	5		
Safety measures	24		
Safety standards	24		
Self-locking	72		
Self-retaining	33		
Serial number	8, 9, 10		
Service	70		
Servicing	70		
Setpoint - indication on display	41		
Short-circuit protection	23		
Signals	47		
Signals (analogue)	47		
Size	10		
Spare parts	79		
Standards	5		
Status menu	35		
Status signals	47		
Status signals Potential	24		
Stem	55		
Stem nut	17		
Stem protection tube	21		
Storage	14		
Supply networks	23		
Support	70		
Support App	11, 11		
T			
Technical data	72		
Temperature protection	9		
Terminal plan	23, 73		
Test run	53		
Torque - indication on display	40		
Torque range	8		
Torque switching	50		
Transport	12		
Type (device type)	10		
Type designation	8, 9		
Type of duty	9, 72		
Type of lubricant	8		
Type of networks	23		
U			
User level	36		
V			
Valve attachment	73		
Valve position - indication on display	40		
Valve stem	21		
Voltage range	23		
W			
Wall bracket	29		
Warnings - indication on display	43		
Wiring diagram	10, 23		

Europe

AUMA Riester GmbH & Co. KG

Location Muellheim
DE 79373 Muellheim
 Tel +49 7631 809 - 0
 info@auma.com
 www.auma.com

Location Ostfildern-Nellingen
DE 73747 Ostfildern
 Tel +49 711 34803 - 0
 riester@wof.auma.com

Service-Center Bayern
DE 85386 Eching
 Tel +49 81 65 9017- 0
 Riester@scb.auma.com

Service-Center Köln
DE 50858 Köln
 Tel +49 2234 2037 - 900
 Service@sck.auma.com

Service Center Magdeburg
DE 39167 Niederndodeleben
 Tel +49 39204 759 - 0
 Service@scm.auma.com

AUMA-Armaturentriebe Ges.m.b.H.
AT 2512 Tribuswinkel
 Tel +43 2252 82540
 office@auma.at
 www.auma.at

AUMA BENELUX B.V. B. A.
BE 8800 Roeselare
 Tel +32 51 24 24 80
 office@auma.be
 www.auma.nl

ProStream Group Ltd.
BG 1632 Sofia
 Tel +359 2 9179-337
 valtchev@prostream.bg
 www.prostream.bg

OOO "Dunkan-Privod"
BY 220004 Minsk
 Tel +375 29 6945574
 belarus@auma.ru
 www.zatvor.by

AUMA (Schweiz) AG
CH 8965 Berikon
 Tel +41 566 400945
 RettichP.ch@auma.com

AUMA Servopohony spol. s.r.o.
CZ 250 01 Brandýs n.L.-St.Boleslav
 Tel +420 326 396 993
 auma-s@auma.cz
 www.auma.cz

GRØNBECH & SØNNER A/S
DK 2450 København SV
 Tel +45 33 26 63 00
 GS@g-s.dk
 www.g-s.dk

IBEROPLAN S.A.
ES 28027 Madrid
 Tel +34 91 3717130
 iberoplan@iberoplan.com

AUMA Finland Oy
FI 02230 Espoo
 Tel +358 9 5840 22
 auma@auma.fi
 www.auma.fi

AUMA France S.A.R.L.
FR 95157 Taverny Cedex
 Tel +33 1 39327272
 info@auma.fr
 www.auma.fr

AUMA ACTUATORS Ltd.
GB Clevedon, North Somerset BS21 6TH
 Tel +44 1275 871141
 mail@auma.co.uk
 www.auma.co.uk

D. G. Bellos & Co. O.E.
GR 13673 Acharnai, Athens
 Tel +30 210 2409485
 info@dgbellos.gr

APIS CENTAR d. o. o.
HR 10437 Bestovje
 Tel +385 1 6531 485
 auma@apis-centar.com
 www.apis-centar.com

Fabo Kereskedelmi és Szolgáltató Kft.
HU 8800 Nagykanizsa
 Tel +36 93/324-666
 auma@fabo.hu
 www.fabo.hu

Falkinn HF
IS 108 Reykjavik
 Tel +00354 540 7000
 os@falkinn.is
 www.falkinn.is

AUMA ITALIANA S.r.l. a socio unico
IT 20023 Cerro Maggiore (MI)
 Tel +39 0331 51351
 info@auma.it
 www.auma.it

AUMA BENELUX B.V.
LU Leiden (NL)
 Tel +31 71 581 40 40
 office@auma.nl

NB Engineering Services
MT ZBR 08 Zabbar
 Tel + 356 2169 2647
 nikibel@onvol.net

AUMA BENELUX B.V.
NL 2314 XT Leiden
 Tel +31 71 581 40 40
 office@auma.nl
 www.auma.nl

SIGUM A. S.
NO 1338 Sandvika
 Tel +47 67572600
 post@sifag.no

AUMA Polska Sp. z o.o.
PL 41-219 Sosnowiec
 Tel +48 32 783 52 00
 biuro@auma.com.pl
 www.auma.com.pl

AUMA-LUSA Representative Office, Lda.
PT 2730-033 Barcarena
 Tel +351 211 307 100
 geral@aumalusa.pt

SAUTECH
RO 011783 Bucuresti
 Tel +40 372 303982
 office@sautech.ro

OOO PRIWODY AUMA
RU 141402 Khimki, Moscow region
 Tel +7 495 221 64 28
 amarusia@auma.ru
 www.auma.ru

OOO PRIWODY AUMA
RU 125362 Moscow
 Tel +7 495 787 78 21
 amarusia@auma.ru
 www.auma.ru

ERICHs ARMATUR AB
SE 20039 Malmö
 Tel +46 40 311550
 info@erichsarmatur.se
 www.erichsarmatur.se

ELSO-b, s.r.o.
SK 94901 Nitra
 Tel +421 905/336-926
 office@elsob.sk
 www.elsob.sk

Auma Endüstri Kontrol Sistemleri Limited
 Sirketi
TR 06810 Ankara
 Tel +90 312 217 32 88
 info@auma.com.tr

AUMA Technology Automations Ltd
UA 02099 Kiev
 Tel +38 044 586-53-03
 auma-tech@aumatech.com.ua

Africa

Solution Technique Contrôle Commande
DZ Bir Mourad Rais, Algiers
 Tel +213 21 56 42 09/18
 stcco@wissal.dz

A.T.E.C.
EG Cairo
 Tel +20 2 23599680 - 23590861
 contactus@atec-eg.com

SAMIREG
MA 203000 Casablanca
 Tel +212 5 22 40 09 65
 samireg@menara.ma

MANZ INCORPORATED LTD.
NG Port Harcourt
 Tel +234-84-462741
 mail@manzincorporated.com
 www.manzincorporated.com

AUMA South Africa (Pty) Ltd.
ZA 1560 Springs
 Tel +27 11 3632880
 aumasa@mweb.co.za

America

AUMA Argentina Rep. Office
AR Buenos Aires
 Tel +54 11 4737 9026
 contacto@aumaargentina.com.ar

AUMA Automação do Brazil Ltda.
BR Sao Paulo
 Tel +55 11 4612-3477
 contato@auma-br.com

TROY-ONTOR Inc.
CA L4N 8X1 Barrie, Ontario
 Tel +1 705 721-8246
 troy-ontor@troy-ontor.ca

AUMA Chile Representative Office
CL 7870163 Santiago
 Tel +56 2 2821 4108
 claudio.bizama@auma.com

B & C Biosciences Ltda.
CO Bogotá D.C.
 Tel +57 1 349 0475
 proyectos@bycenlinea.com
 www.bycenlinea.com

AUMA Región Andina & Centroamérica
EC Quito
 Tel +593 2 245 4614
 auma@auma-ac.com
 www.auma.com

Corsusa International S.A.C.
PE Miraflores - Lima
 Tel +51 1444-1200 / 0044 / 2321
 corsusa@corsusa.com
 www.corsusa.com

Control Technologies Limited
TT Marabella, Trinidad, W.I.
 Tel + 1 868 658 1744/5011
 www.cntltech.com

AUMA ACTUATORS INC.
US PA 15317 Canonsburg
 Tel +1 724-743-AUMA (2862)
 mailbox@auma-usa.com
 www.auma-usa.com

Suplibarca
VE Maracaibo, Estado, Zulia
 Tel +58 261 7 555 667
 suplibarca@intercable.net.ve

Asia

AUMA Actuators UAE Support Office
AE 287 Abu Dhabi
 Tel +971 26338688
 Nagaraj.Shetty@auma.com

AUMA Actuators Middle East
BH 152 68 Salmabad
 Tel +97 3 17896585
 salesme@auma.com

Mikuni (B) Sdn. Bhd.
BN KA1189 Kuala Belait
 Tel + 673 3331269 / 3331272
 mikuni@brunet.bn

AUMA Actuators (China) Co., Ltd.
CN 215499 Taicang
 Tel +86 512 3302 6900
 mailbox@auma-china.com
 www.auma-china.com

PERFECT CONTROLS Ltd.
HK Tsuen Wan, Kowloon
 Tel +852 2493 7726
 joeip@perfectcontrols.com.hk

PT. Carakamas Inti Alam
ID 11460 Jakarta
 Tel +62 215607952-55
 auma-jkt@indo.net.id

AUMA INDIA PRIVATE LIMITED.
IN 560 058 Bangalore
 Tel +91 80 2839 4656
 info@auma.co.in
 www.auma.co.in

ITG - Iranians Torque Generator
IR 13998-34411 Teheran
 +982144545654
 info@itg-co.ir

Trans-Jordan Electro Mechanical Supplies
JO 11133 Amman
 Tel +962 - 6 - 5332020
 Info@transjordan.net

AUMA JAPAN Co., Ltd.
JP 211-0016 Kawasaki-shi, Kanagawa
 Tel +81-(0)44-863-8371
 mailbox@auma.co.jp
 www.auma.co.jp

DW Controls Co., Ltd.
KR 153-702 Gasan-dong, GeumChun-Gu,, Seoul
 Tel +82 2 2624 3400
 import@actuatorbank.com
 www.actuatorbank.com

Al-Arfaj Engineering Co WLL
KW 22004 Salmiyah
 Tel +965-24817448
 info@arfajengg.com
 www.arfajengg.com

TOO "Armaturny Center"
KZ 060005 Atyrau
 Tel +7 7122 454 602
 armacentre@bk.ru

Network Engineering
LB 4501 7401 JBEIL, Beirut
 Tel +961 9 944080
 nabil.ibrahim@networkenglb.com
 www.networkenglb.com

AUMA Malaysia Office
MY 70300 Seremban, Negeri Sembilan
 Tel +606 633 1988
 sales@auma.com.my

Mustafa Sultan Science & Industry Co LLC
OM Ruwi
 Tel +968 24 636036
 r-negi@mustafasultan.com

FLOWTORK TECHNOLOGIES CORPORATION
PH 1550 Mandaluyong City
 Tel +63 2 532 4058
 flowtork@pltdsl.net

M & C Group of Companies
PK 54000 Cavalry Ground, Lahore Cantt
 Tel +92 42 3665 0542, +92 42 3668 0118
 sales@mcss.com.pk
 www.mcss.com.pk

Petrogulf W.L.L.
QA Doha
 Tel +974 44350151
 pgulf@qatar.net.qa

AUMA Saudi Arabia Support Office
SA 31952 Al Khobar
 Tel + 966 5 5359 6025
 Vinod.Fernandes@auma.com

AUMA ACTUATORS (Singapore) Pte Ltd.
SG 569551 Singapore
 Tel +65 6 4818750
 sales@auma.com.sg
 www.auma.com.sg

NETWORK ENGINEERING
SY Homs
 +963 31 231 571
 eyad3@scs-net.org

Sunny Valves and Intertrade Corp. Ltd.
TH 10120 Yannawa, Bangkok
 Tel +66 2 2400656
 mainbox@sunnyvalves.co.th
 www.sunnyvalves.co.th

Top Advance Enterprises Ltd.
TW Zhonghe City, Taipei Hsien (235)
 Tel +886 2 2225 1718
 support@auma-taiwan.com.tw
 www.auma-taiwan.com.tw

AUMA Vietnam Hanoi RO
VN Hanoi
 +84 4 37822115
 chienguyen@auma.com.vn

Australia

BARRON GJM Pty. Ltd.
AU NSW 1570 Artarmon
 Tel +61 2 8437 4300
 info@barron.com.au
 www.barron.com.au

auma[®]

Solutions for a world in motion

AUMA Riester GmbH & Co. KG

P.O. Box 1362

DE 79373 Muellheim

Tel +49 7631 809 - 0

Fax +49 7631 809 - 1250

info@auma.com

www.auma.com



Y004.761/003/en/1.18